



METIS

Research and Innovation Action (RIA)

This project has received funding from the European
Union's Horizon 2020 research and innovation programme
under grant agreement No 945121

Start date : 2020-09-01 Duration : 57 Months

Assessment of new or improved PSA approaches

Authors : Mr. Oleksandr SEVBO (Energorisk)

METIS - Contract Number: 945121

Project officer: Katerina PTACKOVA

Document title	Assessment of new or improved PSA approaches
Author(s)	Mr. Oleksandr SEVBO
Number of pages	64
Document type	Deliverable
Work Package	WP7
Document number	D7.7
Issued by	Energorisk
Date of completion	2024-11-18 14:03:38
Dissemination level	Public

Summary

The present deliverable is focused on discussion of epistemic uncertainties, on modelling approaches for seismic correlations and human performance, vector valued analyses, and consideration of multiple units and multiple radiation sources at a nuclear site. The aim is to offer PSA practitioners guidance on modelling various seismic-related factors. It also deals with the recommendations/proposals for modelling of selected aspects in the framework of METIS study case. The main results of the efforts are: - Overview of methods for modelling of seismic correlations, development of examples and proposals for the METIS study case regarding evaluation/ modelling of the correlations; - Evaluation of impact of seismic events on human performance, considerations regarding selection of HRA methods for seismic PSA, as well proposals on new multiplication coefficients for re-evaluation of human error probabilities; - Literature-based overview of scalar and vector valued analyses for seismic PSA.

Approval

Date	By
2024-11-18 14:04:05	Mr. Oleksandr SEVBO (Energorisk)
2024-11-18 14:10:27	Dr. Irmela ZENTNER (EDF)

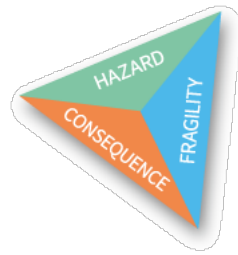

METIS

Seismic Risk Assessment
for Nuclear Safety

Research & Innovation Action

NFRP-2019-2020

Assessment of new or improved PSA approaches

Deliverable D7.7

Version N°1

Authors: Oleksandr SEVBO (Energorisk)



This project has received funding from the Horizon 2020 programme under grant agreement n°945121. The content of this presentation reflects only the author's view. The European Commission is not responsible for any use that may be made of the information it contains.



Disclaimer

The content of this deliverable reflects only the author's view. The European Commission is not responsible for any use that may be made of the information it contains.





Document Information

Grant agreement	945121
Project title	Methods And Tools Innovations For Seismic Risk Assessment
Project acronym	METIS
Project coordinator	Dr. Irmela Zentner, EDF
Project duration	1 st September 2020 – 31 May 2025 (57 months)
Related work package	WP7 - PSA Tools and Methodology
Related task(s)	Task 7.4.1: Representative benchmark
Lead organisation	Energorisk
Contributing partner(s)	
Due date	30 April 2024
Submission date	18 November 2024
Dissemination level	Public

History

Version	Submitted by	Reviewed by	Date	Comments
N°1	O. SEVBO	Robert Budnitz Nilesh Chokshi John Richards	29 October 2024	





Table of Contents

- 1. General discussion of uncertainties in seismic psa 11
- 2. Correlated failures..... 12
 - 2.1. Determining degree of correlation 21
 - 2.2. Incorporation of correlations into seismic PSA model 25
 - 2.3. Way for the METIS study case 28
 - 2.3.1. Overall steps..... 28
 - 2.3.2. METIS study case..... 29
- 3. Multiple units and multiple radiation sources at a site..... 32
- 4. Vector valued analyses 34
 - 4.1. Probabilistic Seismic Hazard Analysis 35
 - 4.2. Fragility analysis 37
- 5. Human performance 42
 - 5.1. Seismic impact on HRA 42
 - 5.2. Seismic HRA..... 51
- 6. Conclusions 55
- 7. Bibliography 56





List of figures

Figure 1: The full Monte Carlo simulation scheme for seismic dependency modelling, /RESS 2024/...	14
Figure 2: Basic concept of Discrete Probability Distribution method /Kaplan 1987/	15
Figure 3: Basic concepts in the Extended Common Load Model, /SSM 2017/	16
Figure 4: Scheme of the Reed-McCann method for seismic dependency modelling, /RESS 2024/.....	17
Figure 5: Scheme of the Bayesian Network method for seismic dependency modelling, /RESS 2024/	18
Figure 6: Probability-consistent Beta-factors vs. correlation coefficient for different values of the total seismic failure probability Q of each individual component/structure, /SMIRT 2011/.....	19
Figure 7: Scheme of the hybrid method for seismic dependency modelling, /RESS 2024/.....	20
Figure 8: Mean partially correlated, fully correlated, and uncorrelated fragilities for example distribution panels, /SMIRT 2022a/.....	22
Figure 9: Mean partially correlated, fully correlated, and uncorrelated fragilities for the example (left - failure of 3/3 components of heat transport system; right - failure of 2/3 components), /SMIRT 1991/.....	23
Figure 10: Fault tree with AND gate (Andromeda code).....	26
Figure 11: Andromeda-SCRAM GUI for CCF groups	27
Figure 12: Flowchart for consideration of correlations.....	28
Figure 13: β - ρ curves for SCG with 2 diesel-generators, for different PGAs	31
Figure 14: β - ρ curves for transformers 0,4 kV, for different PGAs. Left – 2 members in seismic correlation group, right – 3 members.....	31
Figure 15: β - ρ curves for 0,4 kV busbars, for different PGAs. Left – 2 members in seismic correlation group, right – 3 members.	32
Figure 16: β - ρ curves for ZNPP components for PGA 0,3.....	32
Figure 17: Schematic for intra-unit and inter-unit correlations	33
Figure 18: Example of inter-unit correlations.....	34
Figure 19: Seismic hazard curve for single IM. Left for PGA from /ZNPP 2019/, right - PGA for the METIS study case /METIS 2020/.....	36
Figure 20: Seismic hazard surface for spectral accelerations at 4.0 sec and 1.33 sec from VPSHA, /Wang 2015/	37
Figure 21: Mean seismic fragility curves obtained by CDFM, SOV and modified CDFM for PGA, for example SSC, /SMIRT 2022d/.....	39
Figure 22: Mean seismic fragility curves computed for different IM (PGA; SA_1: Absolute spectral acceleration at first frequency, f1; ASI: average absolute spectral acceleration in the range [f1: f1+1Hz]; SVr_1: relative spectral acceleration at first frequency; SrVI: average relative spectral velocity in the range [f1: f1+1Hz]) for example SSC, /NAR 2019/.....	40
Figure 23: Fragility surface, using the two IM: left – vector <PGV, PGA/PGV>, /Gehl 2012/; right – vector <Sa, PGA>, /Zhen 2018/.....	41
Figure 24: Way to model HFE in a fault tree	44





D7.7 Assessment of new or improved PSA approaches

Figure 25: Evolution of HRA methods.....	45
Figure 26: Calculation of the multipliers.....	54





List of tables

Table 1: Approaches for the correlations evaluation 20

Table 2: Rules for Assigning Response Correlation 25

Table 3: Seismic fragility data for selected components, /ZNPP 2019/. 30

Table 4: HRA methods..... 51

Table 5: HDS recommendations..... 53





Abbreviations and Acronyms

Acronym	Description
AC	Alternate Current
ASEP	Accident Sequence Evaluation Program
ATHEANA	A Technique for Human Event Analysis
BBN	Bayesian Belief Networks
BC	Basic Condition
CBDT	Cause-Based Decision Tree
CCF	Common Cause Failures
CDF	Core Damage Frequency
CDFM	Conservative Deterministic Failure Margin
CLM	Common Load Model
COREX	Correlation Explicit
CREAM	Cognitive Reliability and Error Analysis Method
DBE	Design Basis Earthquake
DG	Diesel Generator
EDP	Engineering Demand Parameter
EES	Engineering Significance Events
EOC	Errors of Commission
EPRI	Electric Power Research Institute
GM	Ground Motion
GUI	Graphical User Interface
HCLPF	High Confidence of Low Probability Failure
HCR/ORE	Human Cognitive Reliability / Operator Reliability Experiments
HDS	HRA Damage States
HEP	Human Error Probability
HFE	Human failure events
HRA	Human Reliability Analysis
IAEA	International Atomic Energy Agency
IDAC	Information, Decision and Action in a Crew
IDHEAS	An Integrated Human Event Analysis System





IM	Intensity Measure
LERF	Large Release Frequency, Large Early Release Frequency
MCR	Main Control Room
MCS	Minimal Cut Set
MERMOS	Methode d'Evaluation de la Realisation des Missions Operateur la Surete
MU	Multi-unit
NPP	Nuclear Power Plant
PGA	Peak Ground Acceleration
PGV	Peak Ground Velocity
PIF	Performance Influencing Factor
POS	Plant Operational States
PSA	Probabilistic Safety Assessment
PSF	Performance-Shaping Factor
PSHA	Probabilistic Seismic Hazard Analysis
SAMG	Severe Accident Management Guidelines
SCG	Seismic Correlation Group
SF	Split Fraction
SFP	Spent Fuel Pool
SHARP	Systematic Human Action Reliability Procedure
SLIM-MAUD	Success Likelihood Index Methodology & Multi-Attribute Utility Decomposition
SOV	Separation of variables
SPAR-H	Standard Plant Analysis Risk HRA
SPSA	Seismic Probabilistic Safety Assessment
SSC	Systems, Structures and Components
SSE	Safe-shutdown earthquake
SU	Single-unit
THERP	Technique for Human Error Rate Prediction
TMM	Tail-oriented Multi-normal Model
TRC	Time/reliability Correlation
VPSHA	Vector-valued Probabilistic Seismic Hazard Analysis
WWER	Water-Water Energetic Reactor





WP	Work Package
ZNPP	Zaporizhzhia NPP (Ukraine)

Summary

The present deliverable is focused on discussion of epistemic uncertainties, on modelling approaches for seismic correlations and human performance, vector valued analyses, and consideration of multiple units and multiple radiation sources at a nuclear site. The aim is to offer PSA practitioners guidance on modelling various seismic-related factors. It also deals with the recommendations/proposals for modelling of selected aspects in the framework of METIS study case. The main results of the efforts are:

- ▶ Overview of methods for modelling of seismic correlations, development of examples and proposals for the METIS study case regarding evaluation/ modelling of the correlations;
- ▶ Evaluation of impact of seismic events on human performance, considerations regarding selection of HRA methods for seismic PSA, as well proposals on new multiplication coefficients for re-evaluation of human error probabilities;
- ▶ Literature-based overview of scalar and vector valued analyses for seismic PSA.

The topics were selected taking into account several considerations:

- ▶ They should be associated with high-medium degree of uncertainties in terms of results of seismic probabilistic safety assessments;
- ▶ There is a wide variety of modelling methods, many of which are still under development. This requires a recommendation on the methods selection and implementation.

Keywords

Fragility; correlated failures; uncertainty; human performance; vector-valued analyses; seismic PSA





Introduction

The purpose of this deliverable D7.7 is to assess new modelling approaches for the propagation of epistemic uncertainties, vector valued analyses, and consideration of multiple units and multiple radiation sources at a nuclear site, with intention to provide PSA practitioners with recommendations regarding modelling of different seismic-related aspects.

Section 1 deals with general discussion of uncertainties in seismic probabilistic safety assessments.

Section 2 presents available methods and recommendations for modelling of seismic correlations – correlated failures of systems, structures and components. Proposals for the METIS study case regarding evaluation of the correlations (including correlation coefficients) are also presented.

Discussion of seismic correlations for multi-unit sites is outlined in Section 3.

Overview of different vector-valued analyses for use in seismic probabilistic safety assessments is presented in Section 4.

Evaluation of impact of seismic events on human performance, considerations regarding selection of HRA methods for seismic PSA, as well associated proposals for the METIS study case are included in Section 5.

Section 6 contains conclusions.

1. General discussion of uncertainties in seismic psa

Uncertainties in probabilistic safety assessments (PSA) can be of aleatory and epistemic nature. Aleatory uncertainties are defined as occurring in a random manner. Epistemic uncertainties are associated with state of knowledge, with belief in validity of the probabilistic models and in its predictions of nuclear power plant response to accidents. Aleatory uncertainty is a result of statistical variability, such uncertainty is related to intrinsic randomness and is not reducible as more data is collected for a given model, while epistemic uncertainty can be further reduced by obtaining additional data. In practice, however, the difference between aleatory and epistemic uncertainties is not always clear, since the situations can occur where apparent randomness is actually a result of lack of knowledge.

Seismic PSA (SPSA) deals with both types of uncertainties at different stages of the SPSA process:

- ▶ seismic hazard analysis and estimation of hazard frequencies - uncertainties in seismic hazards;
- ▶ evaluation of systems, structures and components (SSC) fragilities - uncertainties in seismic fragilities;
- ▶ development of PSA models (data analysis, human reliability analysis, system analysis, accident progression modelling, quantification) - uncertainties in random failure rates, operator errors, modelling and completeness.

These uncertainties may have different impact on the results of SPSA. The seismic hazard uncertainty is of the highest significance, uncertainties in seismic fragilities can be ranked as high-medium, while significance of uncertainties in probabilistic models varies from medium to low. General degree of uncertainties is judged below:

- ▶ seismic source characterization – medium;
- ▶ ground motion prediction equations – high;





D7.7 Assessment of new or improved PSA approaches

- ▶ site amplification (high for soil sites, low for rock);
- ▶ seismic fragilities - seismic capacity (includes governing failure mode determination) - medium;
- ▶ seismic response – high
- ▶ logic model (fault trees/event trees) - medium-low;
- ▶ human actions – high-medium;
- ▶ quantification of risk metrics (core damage frequency, fuel damage frequency, radioactive release frequency) – low.

As outlined in /IAEA 2020/, the existence of a high degree of impact of the epistemic uncertainties necessitates a more detailed (comparing to internal events PSA) evaluation and ranking of the results, iterative re-evaluations of some aspects, and an increased attention allocated to the sensitivity and uncertainty analyses. Under the METIS project, uncertainties associated with seismic hazard analysis and seismic fragilities analysis are considered in the work package 4 “Seismic Hazard Analysis”, work package 5 “Ground motion selection for engineering analyses including site response” and work package 6 “Beyond Design and Fragility Analysis”. See, for example /SMIRT 2022b/, or Metis Deliverable 6.6 /METIS 2024/ which is focused on the application of Bayesian updating techniques to reduce the uncertainties on the fragility curves.

This deliverable deals mainly with epistemic uncertainties associated with PSA models.

2. Correlated failures

Earthquakes, especially large earthquakes, are sources for common-cause failures of systems, structures and components. They affect all the components and systems in a nuclear power plant (NPP) unit, as well all facilities /radiation sources at a NPP site. So, earthquakes can cause the simultaneous failure of several redundant safety equipment items. Dependencies between seismic events and failures of systems, structures and components (SSC) should be identified and properly accounted for, since treatment of such dependencies may have a significant impact on the seismic probabilistic safety assessment (PSA) qualitative and quantitative results. For single unit PSA the issue of correlation, like issue of common cause failures, can be important in cases when there is a high-degree of redundancy compared to the success criteria. If there is redundancy (e.g., three-train safety system) and only one train is needed to mitigate an accident sequence, then it may be worth examining the issue of correlation. For multi-unit PSA consideration of correlated failures is more complicated, see Section 3. In a seismic PSA, the component failures represented in a minimal cut set (MCS) may be correlated through their respective responses and fragilities (correlation between component fragilities). Sources of correlation may be: seismic intensity variability correlation; soil and structure amplification correlation; component capacity correlation.

Term correlation here means dependency of failures of SSCs having similar design and plant location that are affected by the same seismic load.

Generally, probabilistic model can contain different failures of SSCs: random failures, noncorrelated seismic failures, groups of correlated seismic failures. While guidelines for treatment of random failures are well matured, approaches for consideration of correlated failures are still under discussion. This is associated with complexity of identifying correlation groups and determining the correlation levels. Moreover, as discussed in /NUR 2017/, earthquake-experience seismic-failure data is not adequate for the purpose of understanding dependencies among failures. That is why estimating correlation parameters using historical failure data from SSCs of similar types under similar seismic loads is not a practical solution.





There are several assumptions that can be adopted for modelling of seismic correlations between SSCs failures:

- ▶ Full correlations;
- ▶ Zero correlations;
- ▶ Partial correlations.

The assumption of full correlations means that failure of one component implies the failure of all components in the group. Such approach is usually recommended for identical components (which are designed, manufactured, delivered, installed, tested, operated, maintained and stressed in parallel) in proximity that are mounted with similar anchorage. Typically, many seismic PSAs, for the sake of simplicity or due to insufficient data regarding correlations or due to limited resources, adopt full correlations approach for such SSCs. In practice, during development of probabilistic models, seismic failures of all identical SSC or all components in a fragility group are modelled as one basic event in a fault tree. Clearly, using full correlation approach is simplified and usually conservative. In some cases, it might be excessively conservative, /IAEA 1993/.

It should be noted, however, that assuming full correlation between SSCs is conservative in cases where the components are in parallel on the success path – so instead of multiplication of several SSC failure probabilities (using AND gate), one failure probability is applied. When the components are in series on the success path, full correlation is not conservative. In this case one failure probability is applied instead of sum of several SSC failure probabilities (using OR gate). Therefore, such aspects should be accounted for during selection of modelling approach for correlated failures.

As opposite to full correlation approach, the assumption of zero correlations or full independence may be appropriate for non-identical SSCs. Clearly, using zero correlation approach for all SSCs (including similar ones) can be sometimes non-conservative.

Dependency among seismic failures in a practical PSA tends to be treated in an approximate manner due to difficulty in calculating combination probabilities of correlated seismic failures, which results from difficulty in determining correlation groups and correlation level. Traditionally, strongly correlated failures can be idealized as one failure and weakly correlated failures are idealized as independent in the logic tree /IAEA 2024a/. So, the almost universal practice among seismic PSA practitioners (as also mentioned in /NUR 2017/) has been to use binary approach - only full or zero response correlation. The current practice for treating seismic correlation in a seismic PSA is to screen out seismically rugged components (for screening recommendations see /METIS 2021/) and then develop correlation groups for the screened-in components to represent the simultaneous failure of similar components during an earthquake. If components are similar in design, with similar anchorage, and located in the same building and elevation, then their failures are treated as fully correlated failures. Otherwise, it is assumed that there is no correlation among component failures, and failures of similar components in different buildings are not correlated.

It should be noted, however, that consideration of partial correlations is needed to avoid excessive conservatism / non-conservatism inherent to binary (full/zero dependency) approach, and to obtain more realistic, more meaningful results of seismic PSA. Some studies have shown that there can be significant decrease in core damage frequency (CDF) with assuming partial correlations instead of complete correlations. E.g. /KNS 2019/ demonstrates about 20%-40% reduction in CDF for a test case.

Various guidance exists concerning how to model correlations between seismic failures of components under various circumstances. A review of such guidance is presented in several references, e.g. /EPRI 2013/, /NRC 2017/, /RESS 2024/, etc. Table 1 briefly represents available approaches for consideration of correlations.





Approach	Description
<p>Monte Carlo Simulation method /NUS 1983/, /NUR 2017/</p>	<p>Random sampling from a continuous probability density function. The technique is used to handle the seismic correlation and repeat the process of randomly determining the failure due to seismic impacts. This approach can easily and accurately calculate the failure probability of a system modelled in the fault tree format. Non-seismic failures can also be handled.</p> <p>Monte Carlo Simulation scheme is illustrated on Figure 1. There are three main parts, /RESS 2024/: (a) generate sample sets of ground motion intensity to propagate uncertainty of seismic hazard, otherwise, use a fixed intensity of ground motion; (b) generate sample set of dependent ground acceleration capacity using the multivariate normal distribution or a more general joint probability distributions using copulas; (c) use the random sample sets of ground motion and ground acceleration capacity to determine the component state and then estimate the system risk according to the system configuration.</p> <div data-bbox="443 775 1369 1451" style="text-align: center;"> </div> <p>Figure 1: The full Monte Carlo simulation scheme for seismic dependency modelling, /RESS 2024/</p>
<p>Latin hypercube sampling</p>	<p>Random sampling from a continuous probability density function. Differs from Monte Carlo Simulation in that a stratified sampling algorithm is used to span the probability space efficiently, thereby reducing the required number of trials, /NUR 2017/</p>
<p>Discrete Probability Distribution method, /Kaplan 1987/</p>	<p>Discretization of analytical probability density functions into discrete probability distributions. The method can handle two extreme cases of dependence between component failures, i.e., either zero or full dependency in randomness and uncertainty.</p>





Approach	Description
----------	-------------

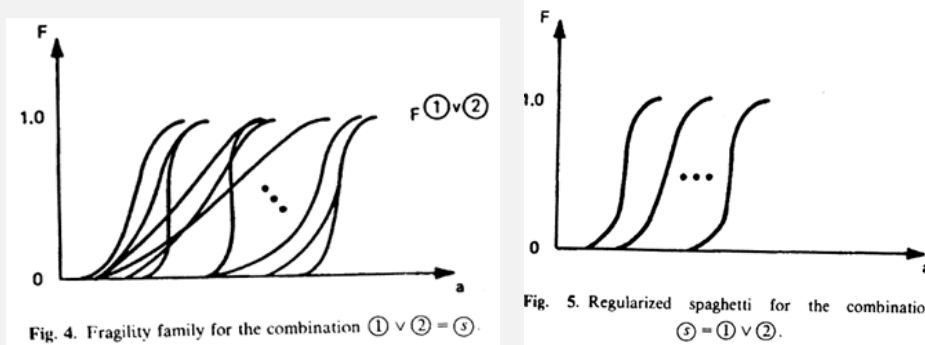
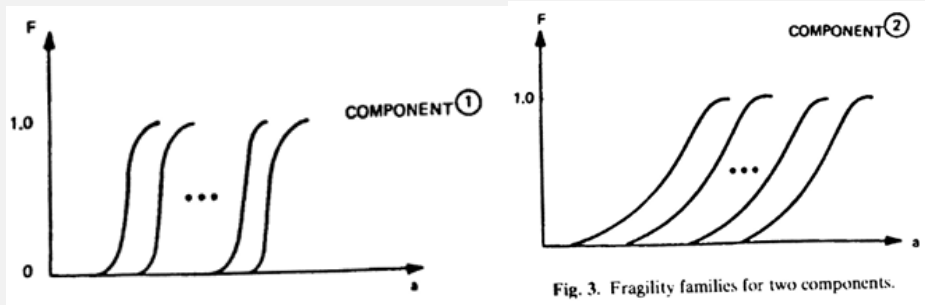

Figure 2: Basic concept of Discrete Probability Distribution method /Kaplan 1987/

Multiple integration method (Seismic Safety Margins Research Program), /NUR 1986/, /NUR 1990a/

In the program, the local responses of different components located at different elevations in various buildings were represented by a joint lognormal distribution; similarly, the capacities of these components were also represented by a joint lognormal distribution. The correlation between any two component failures is computed from:

$$\rho_{12} = \frac{\beta_{R1}\beta_{R2}}{\sqrt{\beta_{R1}^2 + \beta_{F1}^2}\sqrt{\beta_{R2}^2 + \beta_{F2}^2}}\rho_{R1R2} + \frac{\beta_{F1}\beta_{F2}}{\sqrt{\beta_{R1}^2 + \beta_{F1}^2}\sqrt{\beta_{R2}^2 + \beta_{F2}^2}}\rho_{F1F2}$$

Correlation between component failures is a function of the logarithmic standard deviations of responses and fragilities (capacities).

There are sets of rules developed in /NUR 1986/, /NUR 1990a/ for evaluation of the correlated failures. It is worthwhile noting that the validity of applying the Seismic Safety Margins Research Program rules to modern NPPs must be further investigated since the dependent features could be changed given the evolving development of seismic hazards, fragility evaluation, and reactor design.

Common Load Model, /VTT 1977/,

Extended Common Load Model, /SSM 2017/

The basic assumption of the model is that redundant components are operating under common load or stress, which is a random variable. The strengths of the components are independent and identically distributed random variables, and a failure occurs when the load exceeds the strength, see Figure 3.

The probability that k out of n components fail is according to the Common Load Model (CLM)

$$P_{(k \text{ component out of } n \text{ fail})} = \binom{n}{k} \int_x F_R(x)^k (1 - F_R(x))^{n-k} f_L(x) dx ,$$





Approach	Description
<p>(Mankamo Model in /NUR 2017/)</p>	<p>where $f_L(x)$ is the probability density function of the common load and $F_R(x)$ is the cumulative distribution of the strength (resistance) of the components. In the original CLM, the distributions of the common load and component resistances are Gaussian. Because there is some evidence that the multiple failures of highly redundant systems (more than 4) may have stronger dependence, Mankamo /SSM 2017/ introduced the Extended Common Load Model, in which the load variable is described by a two component Gaussian distribution.</p> <p>Figure 3: Basic concepts in the Extended Common Load Model, /SSM 2017/</p>
<p>Reed-McCann method, /Reed 1985/, /NUR 2017/</p>	<p>The key idea of the method is to identify the component-specific variability and common variability between the fragilities of SSCs. One can then determine their composite correlation of ground acceleration capacities, regardless of the magnitude of ground motion. The method uses a two-stage process to estimate dependency between component failures by searching for common sources of variability in the response and strength calculations, see Figure 4. The dependency in the structural parameters can be quantified by examining the process in which the individual factors of safety in a fragility assessment are developed. First, the common sources of randomness and uncertainty should be identified. Then numerically quantify the joint fragility by a two-stage process. In the first stage, the median capacities are sampled, for example, by using the Latin Hypercube Sampling method, considering the dependencies among uncertainties. In the second stage, for each set of correlated median capacity values, a single system fragility curve is calculated which reflects the dependency in the capacity values conditional on known correlated median values.</p>



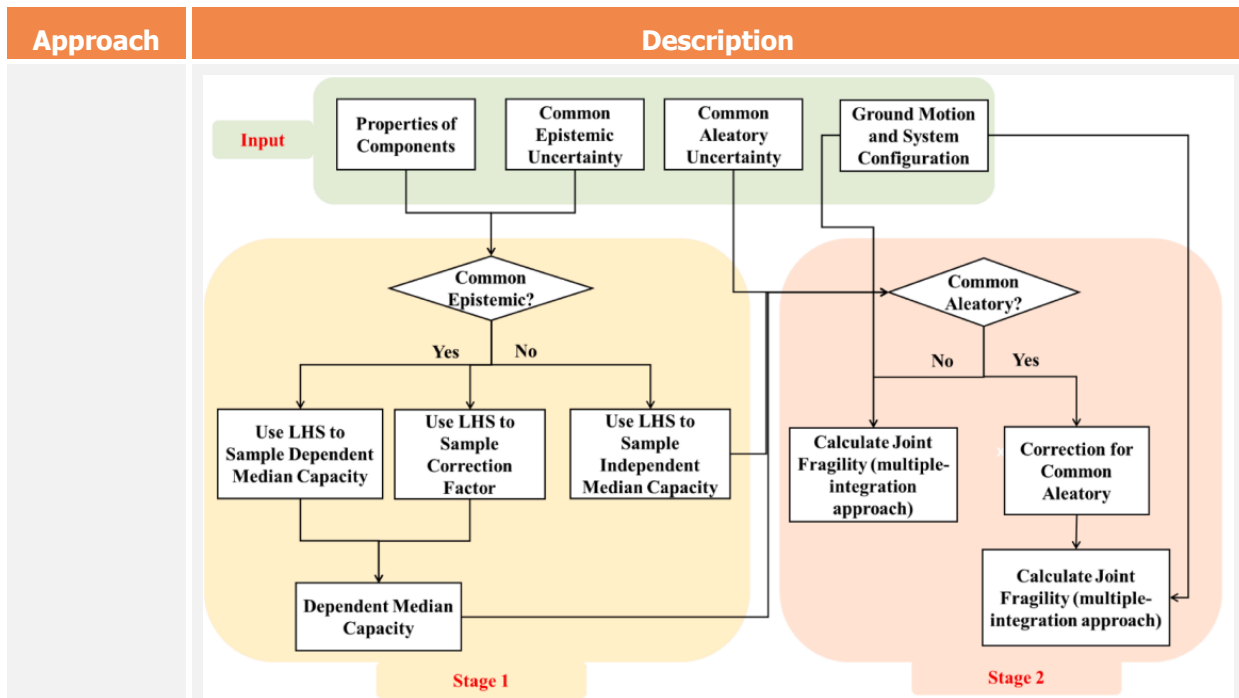

Figure 4: Scheme of the Reed-McCann method for seismic dependency modelling, /RESS 2024/

The degree of fragility correlation between two SSCs can be represented by a fragility correlation coefficient

$$\rho = \frac{(\beta^*)^2}{\beta_1\beta_2} ,$$

Where β_1 and β_2 are fragility variabilities (logarithmic standard deviations) associated with SSCs 1 and 2, and β^* is the common or correlated portion of β_1 and β_2 . For a given pair of SSCs, two types of fragility correlation coefficients can be defined: ρ_R (relates the logarithmic standard deviations for randomness, β_R between the SSCs) and ρ_U (relates the logarithmic standard deviations for uncertainty, β_U). Note that β_1 , β_2 , and ρ can correspond to the total fragility variabilities, or to a particular fragility variable, e.g., equipment response.

According to /NUR 2017/, the Reed-McCann method could be an excellent basis for deriving correlation numbers that could vary across the fragility curve as a function of seismic load. However, some limitations have been identified, as outlined in /Zhou 2017/ - the Reed-McCann method is not performing well to characterize the contribution of dependencies. There are also issues, see /RESS 2021/, with the Reed-McCann method's quantification of the seismic failure probability of a parallel system (i.e., AND failure logic).

Split fraction method, /OECD 1999/, /NUR 2017/, /KNF 2016/, /PSA 2019/

Conceptual approach that was proposed by Fleming and Mikschl, /OECD 1999/, includes the following: first, the fragility analyst defines two different fragility curves for two identical components A and B: one representing the parts of the fragility that are assessed as being primarily dependent (which should include the seismic intensity variability and at least part of the amplification contribution), and one for the parts that are expected to be independent. These two fragility curves are denoted by the superscripts D and I, respectively. Then, the joint failure probability of both components is calculated by equation





Approach	Description
	$F_j\{A * B\} = F_j^D\{A * B\} + [1 - F_j^D\{A * B\}]F_j^I\{A\}F_j^I\{B\}$ <p>As noted in /NUR 2017/, this thinking has led to the recent proposals to cast the seismic dependence problem in the format of "split fraction". Under split fraction (SF) method, the joint failure probability of both components is computed by equation, /KNF 2016/:</p> $P_j(G) = (1 - SF)f_i(G) + SFf_i(G) ,$ <p>where SF - seismic correlation split fraction, fraction of seismic events with common cause failure of similar components due to seismic fragility correlation; $f_i(G)$ - seismic fragility of components in Group G at seismic intensity j. The value of split fraction of zero means zero dependency whereas split fraction of 1.0 means that the components are fully dependent, /NUR 2017/.</p>
<p>Bayesian Network-based Method, /RESS 2021/</p>	<p>Bayesian network-based method for modelling seismic dependencies proposed by /RESS 2021/. The nodes of SSCs states (e.g., C_i denotes the state of i^{th} SSC) depend on the nodes of two sources of variability, which are either component-specific (e.g., ϵ'_i specific to i^{th} SSC), or common to multiple SSCs (e.g., $\epsilon^*_{i,n}$ shared by i^{th} and n^{th} SSC). This enables the mechanism for the treatment of seismic dependencies. Additionally, only the ground motion beyond a certain intensity of ground motion (GM node) can have the potential to meaningfully affect the state of SSCs, which is typically referred to as an earthquake of engineering significance events (EES node). Finally, one can determine the system state (S node) according to the states of SSCs, /RESS 2024/.</p> <div data-bbox="391 1160 1425 1671" data-label="Diagram"> </div> <p>Figure 5: Scheme of the Bayesian Network method for seismic dependency modelling, /RESS 2024/</p> <p>According to benchmark study for three-component system in /RESS 2024/, the Bayesian network method does not perform satisfactorily - we could obtain a conservative risk estimate in the low to medium level of PGA but would possibly underestimate risk in the high level of PGA.</p>





Approach	Description																								
Beta-factor model, /SMIRT 2011/, /SMIRT 2009/, /SMIRT 1991/	<p>Pellisetti and Klapp /SMIRT 2011/, Klugel /SMIRT 2009/ proposed an approach that uses the traditional CCF model for internal events employing beta factors. It was judged that the equivalence hypothesis between the beta-factor and correlation coefficient is not appropriate. The approach for transferring correlation model of NUREG-1150 /NUR 1990/, see also Table 2, to the traditional CCF beta-factor model was developed. For two components, the beta-factor can be derived from equation</p> $P^2\beta^2 + (P - 2P^2)\beta + P^2 = P_{1,2} ,$ <p>where P is failure probability of one component, β is CCF beta factor; $P_{1,2}$ - probability of correlated failure of two components, calculated using correlations both between responses and between capacities of individual components.</p> <p>Example of calibration between beta-factor and correlation coefficients depending on seismic failure probability of component is shown in Figure 6.</p> <table border="1"> <caption>Data points for Figure 6</caption> <thead> <tr> <th>$\rho_{X1,X2}$</th> <th>β (Q=0.003)</th> <th>β (Q=0.5)</th> <th>β (Q=0.9)</th> </tr> </thead> <tbody> <tr> <td>0</td> <td>0</td> <td>0</td> <td>0</td> </tr> <tr> <td>0.1</td> <td>0</td> <td>0.25</td> <td>0.9</td> </tr> <tr> <td>0.5</td> <td>0.1</td> <td>0.6</td> <td>0.95</td> </tr> <tr> <td>0.9</td> <td>0.5</td> <td>0.85</td> <td>0.98</td> </tr> <tr> <td>1</td> <td>1</td> <td>1</td> <td>1</td> </tr> </tbody> </table>	$\rho_{X1,X2}$	β (Q=0.003)	β (Q=0.5)	β (Q=0.9)	0	0	0	0	0.1	0	0.25	0.9	0.5	0.1	0.6	0.95	0.9	0.5	0.85	0.98	1	1	1	1
$\rho_{X1,X2}$	β (Q=0.003)	β (Q=0.5)	β (Q=0.9)																						
0	0	0	0																						
0.1	0	0.25	0.9																						
0.5	0.1	0.6	0.95																						
0.9	0.5	0.85	0.98																						
1	1	1	1																						
Correlation Explicit (COREX) method, /NEAT 2020/	<p>The key idea of the COREX method is to explicitly model seismic dependency by converting correlated seismic failures into seismic CCF. COREX method uses the Reed-McCann method or Seismic Safety Margins Research Program to determine the seismic failure probabilities of all possible combinations; formulate a system of equations (i.e., seismic failures probabilities are the dependent variables and seismic CCF probabilities are the independent variables) and solve the system of equations to estimate seismic CCF probabilities of all the possible combinations.</p> <p>According to benchmarking study for three component system in /RESS 2024/, the COREX method provides acceptable conservatism with a balance between accuracy and computational simplicity in addressing large-scale seismic PSA.</p>																								
Hybrid method, /Zhou 2018/	<p>The approach is based on a hybrid scheme with the simulation-based method to account for the dependencies at the group level of dependent SSCs and a discretization-based scheme at the plant level, see Figure 7.</p>																								



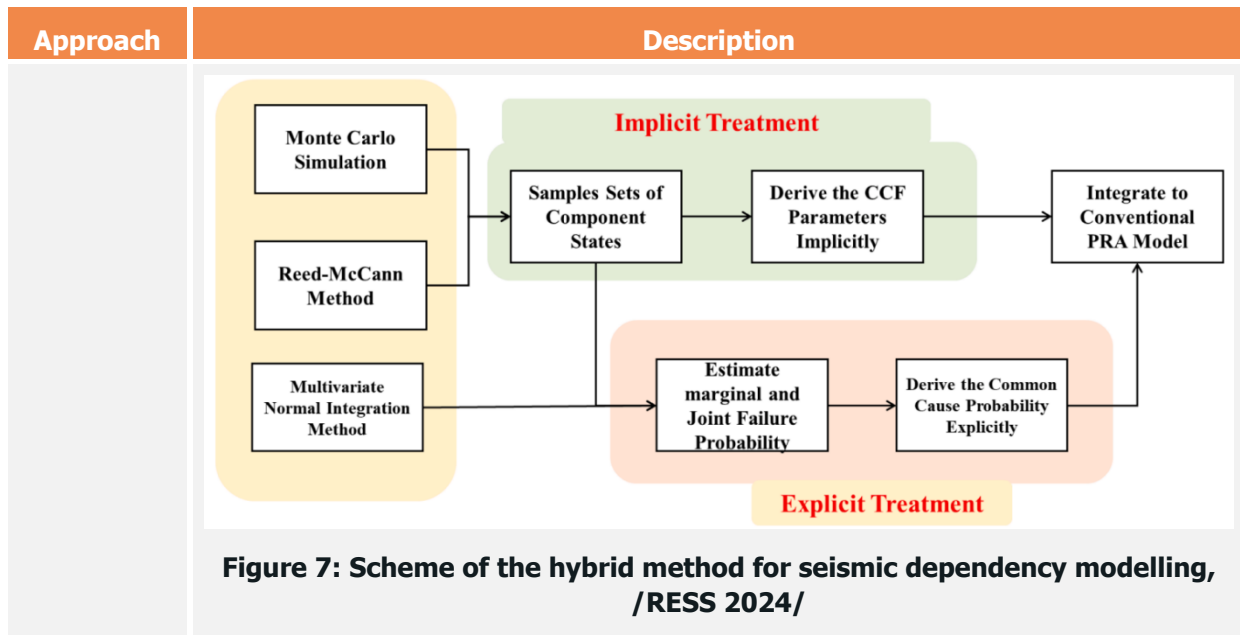

Tail-oriented Multi-normal Model (TMM),

/SMIRT 2022/

The TMM (by Talaat and Anup) follows approach on separation of independent and common variables (as suggested by several methods, e.g. Reed-McCann method). As stated in /SMIRT 2022/, the fundamental difference between it and the Reed-McCann method is that its implementation takes advantage of the normal distribution additive property, whereby the sum of independent, normally distributed random variables is normally distributed with an expected value and variance equal to the sum of expected values and variances, respectively, to efficiently develop a composite fragility for any combination of SSC failures.

The TMM method implementation uses the following steps: 1. Separate the independent and common random variables. 2. Develop the Step-1 composite seismic fragility representing independent variables only. 3. Perform TMM calibration of the Step-1 lognormal fragility. 4. Develop the Step-2 composite fragility combining independent and common variables.

In /SMIRT 2022/ it is outlined that COREX method presents an elegant and efficient solution to incorporating partially correlated seismic fragilities in seismic PSA logic models. The execution of the COREX requires seismic fragility curves for all possible failure combinations within the partially correlated SSCs of interest to the seismic PSA model. The TMM method efficiently develops these composite seismic fragility curves for input to the CCF transformation equations from P to Q probabilities. Integrating the TMM method with the COREX methodology produces an efficient seismic PSA modelling and quantification technology that explicitly incorporates partially correlated failures using commonly used computer codes and tools.

Table 1: Approaches for the correlations evaluation

Summarizing, there are several approaches available to model seismic-induced partial dependencies between similar components. They can be split into the following groups:

- ▶ Analytical and simulation studies to characterize seismic correlations/ dependencies. Such methods as Multiple integration method, Monte Carlo simulation, Common Load Model, are representatives of this group;





D7.7 Assessment of new or improved PSA approaches

- ▶ Separation of independent and common variables - to identify the component-specific variability and common variability between the fragility of SSCs; then determine their composite correlation of ground acceleration capacities, regardless of the magnitude of ground motion. Reed-McCann method, TMM method, Bayesian Network-based Method utilize such approach;
- ▶ Apply traditional to PSA CCF approach to model seismic correlations. Parameters of CCF are indirectly estimated according to the correlation of ground acceleration capacity. COREX method, Beta-factor model, etc. follow this approach. Split fraction approach is also intuitive for PSA analysts.

In practice, there is no ideal approach, analyst should choose between a trade-off of accuracy and cost-effectiveness of the approach, such as the required expertise, calculational time and complexity, accuracy and acceptability of the results.

During consideration of correlations the following crucial tasks should be performed:

- ▶ determination of degree of correlation;
- ▶ incorporation of correlations into seismic PSA model and quantification of results;
- ▶ analysis and interpretation of the results - estimation of the uncertainty in the final seismic-PSA result arising from the correlation analysis.

2.1. Determining degree of correlation

As shown in /NUR 2017/, determination of degree of correlation cannot be statistically-based. That's why expert judgement is widely applied to assign numerical arbitrary values for degree of correlation. NUREG/CR-4840, /NUR 1990a/ provides some general guidance (Bohn thumb rule) for determining the correlation coefficients, to be used for all PGA levels. E.g., Bohn thumb rule states that components on the same floor slab and sensitive to the same spectral frequency range (i.e., spectral acceleration 5-10 Hz. or 10-15 Hz) will be assigned response correlation equal to 1.0.

There are, however, several discussions, see e.g. /NUR 2017/, /KNS 2019/, etc., that though components are the same and installed in the same floor slab in the same building, the seismic correlation may not be one. There are two aspects that can influence on degree of correlation: common seismic failure modes and common seismic excitation. Some example criteria associated with those aspects are provided here: a difference in component location on the floor (i.e. in the center of the room or near the wall); or difference in component orientation; or relatively long distance among components. In addition, for judging about SSC correlations, the following aspects are important: presence of identical support components (e.g., valves, control centers); similar anchorage; similar impingement weaknesses (e.g., several systems installed close to drywell wall). Another aspect that has been investigated is influence of aging on the correlations. Based on the results of this comprehensive test program and the lack of any aging correlation in the earthquake experience data, it is suggested in /EPRI 2018/ that aging in mild environments does not significantly degrade seismic resistance.

Examples in Figure 8 and Figure 9 highlight the importance of proper treatment of correlations in PSA. Partially correlated fragilities in the Figure 8 have been calculated using approach on separation of independent and common variables. Correlation coefficients were assigned for each variable, depending on its type (equipment capacity, equipment response, structural response). Correlation coefficients were 0.8, 0.2, 0.5.

In /SMIRT 2022a/ it is stated that idealization of the correlation as perfectly correlated would have resulted in unconservative characterization of the failure probabilities for concurrent failures, while the perfectly uncorrelated idealization would have resulted in an unconservative union fragility (corresponds





to the concurrent failures of the two components). At the same time, a perfectly uncorrelated idealization for the joint fragility (corresponds to failure of any one of the two components) can result in considerable conservatism, and likewise for a perfectly correlated idealization for a union fragility. If the example components in Figure 8 are risk-significant, then a binary idealization of their fragility correlation can have a potentially significant impact on the single- or multi-unit seismic risk, /SMIRT 2022a/.

Figure 9, however, demonstrates that for more complex systems it is not possible to easily determine the most conservative case. For example, for failure combination 2 out of 3 SSCs, the most conservative assumption is dependent on PGA level.

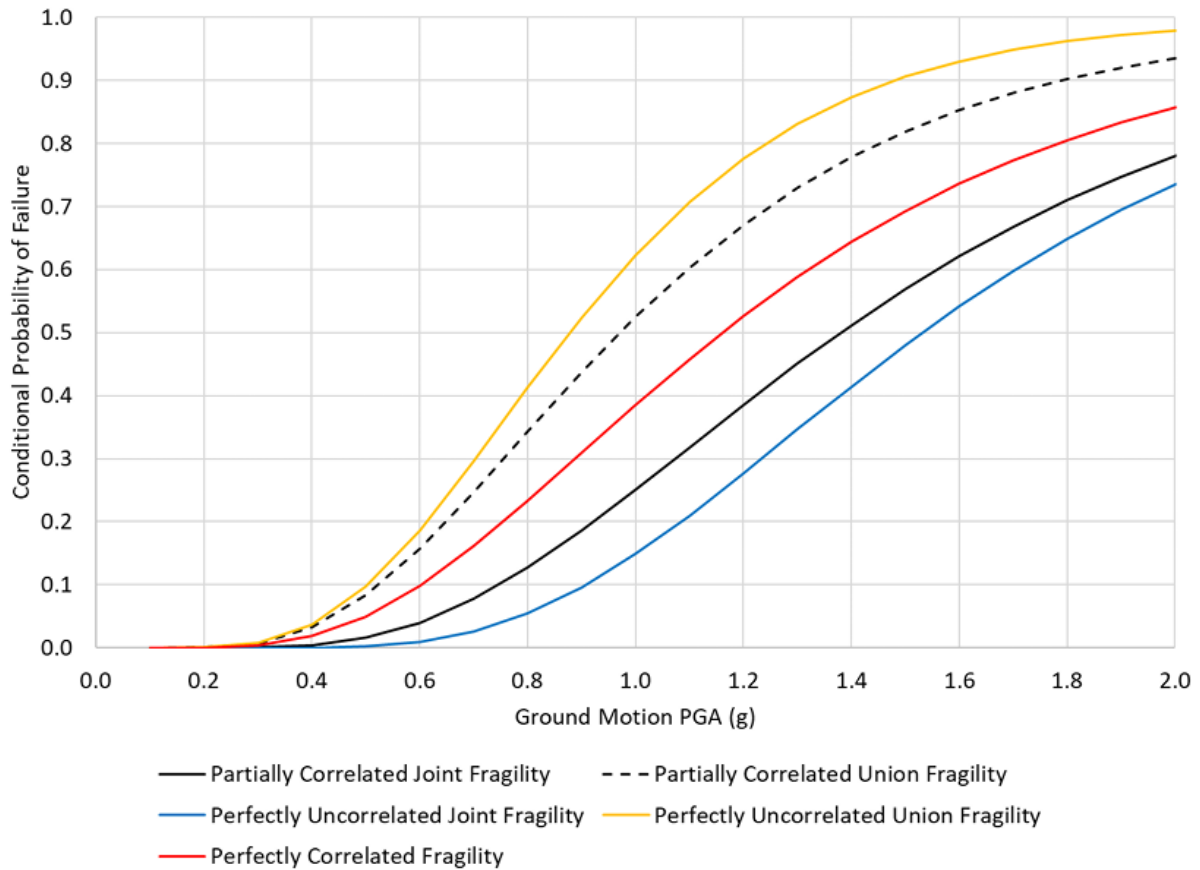

Figure 8: Mean partially correlated, fully correlated, and uncorrelated fragilities for example distribution panels, /SMIRT 2022a/



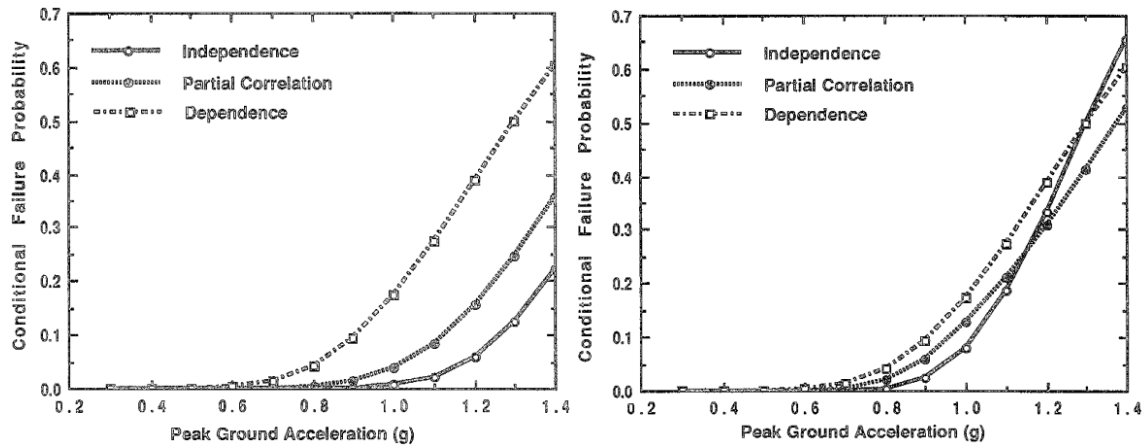

Figure 9: Mean partially correlated, fully correlated, and uncorrelated fragilities for the example (left - failure of 3/3 components of heat transport system; right - failure of 2/3 components), /SMIRT 1991/

Table 2 provides some recommendations for determination of correlation coefficients. The recommendations have been prepared from data provided in several sources, such as /NUR 1990a/, /IAEA 2020/, /SMIRT 2022a/, /NUR 1990/, /EPRI 2013/.

Rule	Comment	Correlation	
		Degree	Coefficient
<p>Components of systems with identical redundant trains are: essentially identical; and located at the same level of the same building; and oriented at the same direction (axis).</p> <p>If, however, there are significant differences in such aspects as components location on the floor; components orientation; distance among components; presence of identical support components; anchorage; impingement weaknesses than lower correlation degree may be chosen (strong-moderate), as showed at row below.</p>	<p>Fragility experts have identified that similar orientation can be used as an argument to support full correlation. However, different orientation should not be used as a sole justification for treatment of SSCs as completely uncorrelated. SSCs failure modes should be also taken into consideration. e.g., for relay and contactor chatter, orientation might be enough.</p>	Full	1
<p>Components of systems with identical redundant trains are: essentially identical; and located at the same level of the same building; but differently oriented.</p>		Strong	0,75-0,8
<p>"Ganged" valve configurations (either parallel or series)</p>		Full	1





Rule	Comment	Correlation	
		Degree	Coefficient
Equipment located within a building is assumed 100% correlated with structural failure of that building	Although some equipment may survive a structural failure of the building in which it resides, it is problematic to attempt to credit such capability, given the uncertain failure response of the building	Full	1
Redundant equipment in different but similarly constructed buildings on the same basemat		Full-strong	0,7-1
Identical components on different floor slabs (but in the same building) and sensitive to the same spectral frequency range	/EPRI 2003/ states that there is a high degree of correlation between items of similar natural frequencies located on different floor elevations. This correlation decreases away from the amplified acceleration range (i.e., increasing frequencies above 14 Hz). The conclusion was that consideration should be given to correlation between controlling seismically induced failure modes for equipment items with similar frequencies in the same structure. Equipment items with similar frequencies located on the base slabs of different structures may be highly correlated since they see similar input motions	Strong	0,75-0,8
Components on the same floor slab sensitive to different ranges of spectral acceleration		Moderate	0,5
For systems that are similar in design and functionality but not identical (or for identical trains with important differences, such as different elevation)	Examples of similar but not identical systems are those that have different key components that share similar support components or serve a similar plant function	Weak-Moderate	0,3-0,5
Components on the same elevation (floor) but in different buildings and	Since the fundamental frequencies of the structures housing these equipment items	Weak-Zero	0-0,3





Rule	Comment	Correlation	
		Degree	Coefficient
sensitive to the same spectral frequency range	are widely separated, it is expected that the correlation between equipment items located in different structures will be low, even for equipment items with similar natural frequencies.		
Identical components that are located on different floors in different buildings		Zero	0
Components with different design, or if SSCs are more than nominally different		Zero	0

Table 2: Rules for Assigning Response Correlation

Walkdowns are an important part of the process for definition of correlated fragility groups. For example, if a NPP has three essential power supply trains with batteries, and one of the three batteries is a different design and size (that is why CCF family for the batteries is 2/2), the seismic engineers may observe that the power conditioning systems are all exactly the same and the dominant failure mode, and thus it may be appropriate to model all three batteries as a single correlated fragility group. Such information, as well as data on SSCs location, orientation, anchoring etc., can be obtained during walkdowns.

2.2. Incorporation of correlations into seismic PSA model

Apparently, there is a difference on understanding of the term "correlation" between PSA engineers and seismic engineers. The term "correlation" can be expressed from seismic engineers' point of view as correlation between random variations representing seismic capacities (e.g., PGAs), while PSA engineers would consider correlation between failure events and their probabilities. The second definition is applied in PSA codes. Thus, there is a need for connection between seismic-intuitive and PSA-intuitive definitions of correlation. The most suitable approaches for this are methods dealing with converting correlated seismic failures into seismic common cause factors. Such methods, as beta-factor method, COREX, as well hybrid method, see Table 1, provides useful ways for such connection. Also, split fraction method is well understandable by PSA practitioners.

The most commonly used approach for common cause modelling in PSA is beta-factor methodology. It assumes that all components belonging to a CCF group fail when that common cause occurs. By definition, this model distinguishes between individual failures and CCFs, with the assumption that if the CCF occurs, all components fail simultaneously by a common cause. Multiple independent failures are neglected. Beta-factor, β , is conditional probability that the common cause of a component failure will be shared by all components. This methodology is conservative (except for groups with two components), but represents a reasonable first approximation. As an initial step for consideration of correlations it is proposed to use beta-factor methodology, to convert correlation coefficients to beta-factor, β . The conversion is performed by equalizing an equation for definition of the probability of the joint failure by beta-factor methodology with equation for definition of the probability of the joint failure





by fragility data. So, unlike an internal events PSA modelling of the CCF, for seismic PSA the values of β -factor would vary depending on the ground motion intensity and the component's capacities.

For example, for system with CCF group with three identical components, when all components have to fail for the system failure (AND gate "IF" at fault tree in Figure 10), system failure probability by the beta-factor methodology is defined by equation:

$$P(A1A2A3) = (1 - \beta)^3 P(A)^3 + \beta P(A) ,$$

where: β is CCF beta-factor, $P(A)=P(A1)=P(A2)=P(A3)$ is failure probability of component.

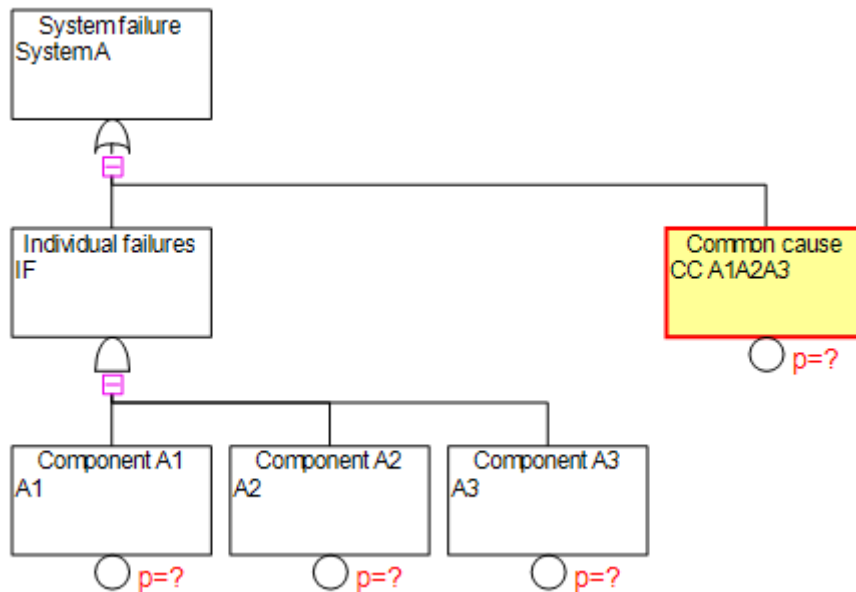

Figure 10: Fault tree with AND gate (Andromeda code)

Probability of the system failure by fragility data ($Q(A1A2A3)$) can be calculated using such equation, as:

$$Q(A1A2A3) = \int_0^\infty \prod_{k=A1,A2,A3} \Phi \left[\frac{1}{\beta_R} \ln \left(\frac{A}{x A_{m,k}} \right) \right] \phi \left(\frac{\ln x}{\beta_R^*} \right) \frac{dx}{x \beta_R^*} ,$$

where: β_R and β_R^* independent and common portions of variabilities, $A_{m,k}$ component's median capacity, Φ is cumulative normal distribution function.

Equalizing equations for $P(A1A2A3)$ with $Q(A1A2A3)$, one can calculate beta-factor.

For system with two redundant components, beta-factor can be obtained from seismic failure probability, P , and correlation coefficient, ρ_{12} by equation, /Zhou 2017/:

$$\beta = \frac{(2P - 1) + \sqrt{(1 - 2P)^2 + 4P * (1 - P) * \rho_{12}}}{2P} ,$$

Depending on PSA code architecture, common cause failures (and correlated failures) can be modelled by two ways:

- ▶ Manually insert in fault trees basic events that represent common cause failures for redundant components (see example in Figure 10). This way is more convenient for visualization of combination of failures leading to undesirable consequences. However, the results depend on



D7.7 Assessment of new or improved PSA approaches

judgment of the analyst. During assigning single failure probability, one should remember that the single failure probability P_s is only portion of total failure probability, P . Ignoring this will lead to overestimation of results. Another aspect is that CCF are modelled only for such configuration of system with redundant components, when the several components have to fail for the system failure (AND logic). When failure of only one component is sufficient for the system failure (OR logic), then common cause failures are typically ignored. This is acceptable for internal events PSA, since the probability of a single failure is at least an order of magnitude higher than the probability of the CCF (for cases with $\beta = 0.1$, and if the multiple Greek letter or alpha factor model was used, the difference is even greater). Assumption on neglecting common cause failures for OR logic may be not suitable for modelling seismic failures, since the coefficients for partial correlations can be equal to 0.5 or 0.7. In this case, the difference between a single seismic failure and a seismic CCF is insignificant. And accordingly, for OR logic, it is also necessary to model a seismic CCF.

- ▶ Introduce CCF group (group composition, CCF model and parameters) for redundant components at logical models solving level. When the editing of the CCF group is complete, the code creates the CCF events (combinations of failures of components included in CCF group). As the next step, each of the basic events that appear in the fault tree is replaced with an OR-gate (called a CCF gate) with all individual failure events and CCF events involving that basic event (component) as input.

The METIS tool (Andromeda-SCRAM) utilizes the second way. Figure 11 presents a screen from the code graphical user interface (GUI) related to modelling of common cause failures. This option will be further used for the METIS study case.

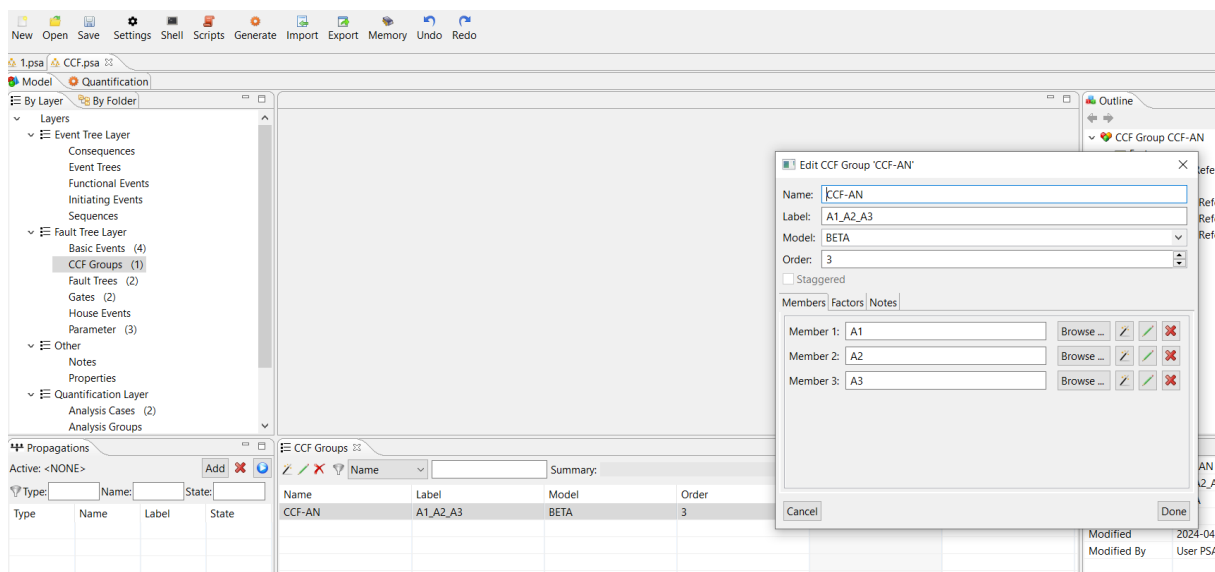

Figure 11: Andromeda-SCRAM GUI for CCF groups

The abovementioned approach is intuitive for PSA practitioners, the correlations can be easily implemented into PSA software; numerical parameters can be readily quantified for small correlation groups. For larger correlation groups with more than 3 components, equalizing equations for system failure probability by the beta-factor methodology with probability of the system failure by fragility data is much more complicated.



2.3. Way for the METIS study case

2.3.1. Overall steps

Development of PSA is an iterative process involving interfaces with most tasks of a seismic PSA. The initial quantification of the safety functions and accident sequences is carried out using the preliminary models and data. On completion of this initial quantification it is possible to identify the dominant accident sequences and concentrate efforts at final quantification on ensuring that the models and data reflect the plant design and operation as accurately as possible. Both uncertainty and sensitivity analyses are included in the final quantification.

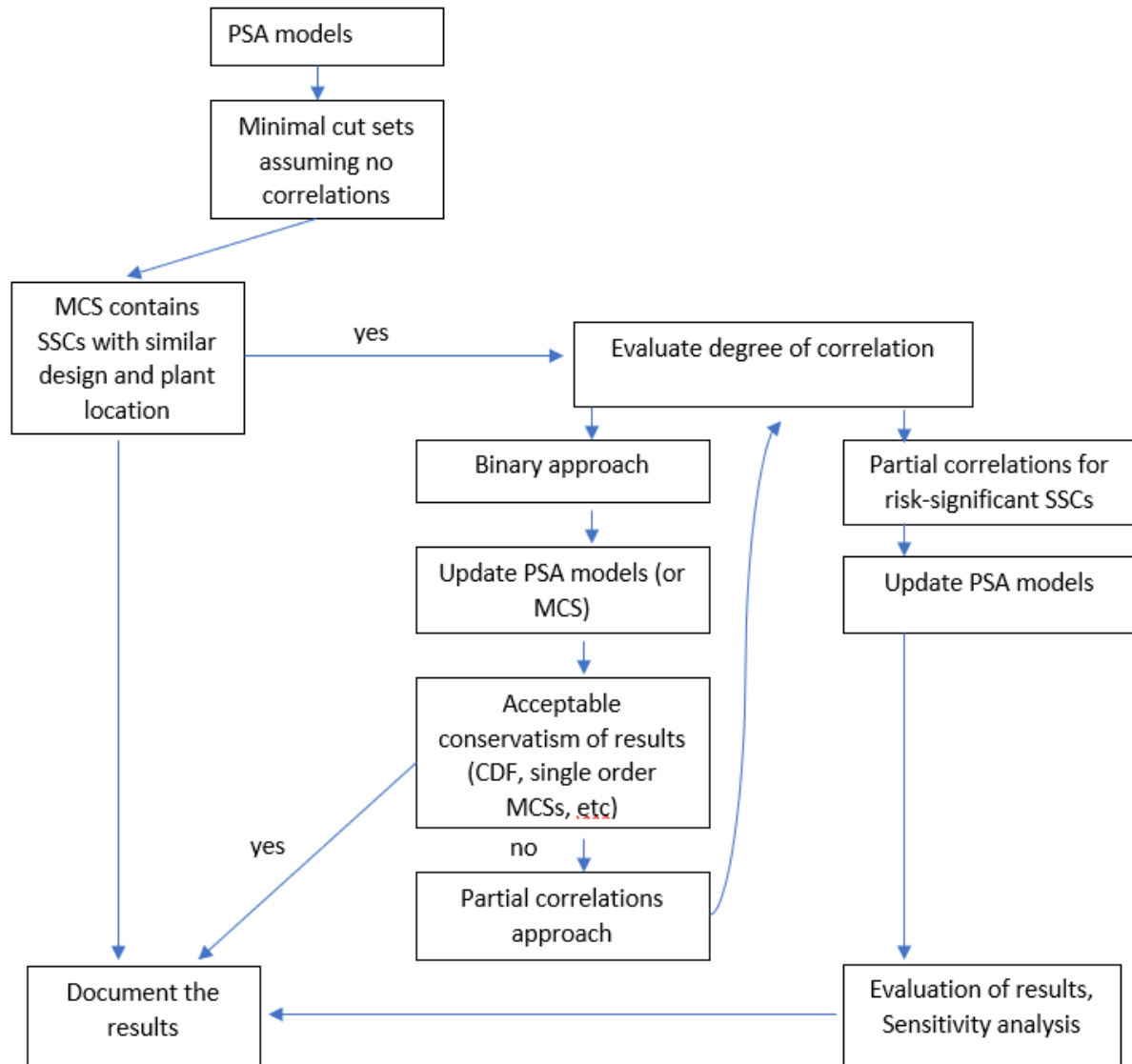

Figure 12: Flowchart for consideration of correlations

Regarding consideration of fragility correlations in seismic PSA, the widely used approach consists of the following stages, see Figure 12. At the first stage, during development of PSA models, consider the binary approach. Use full correlation for redundant components in the same system if they are located at the same elevation in the same building. Redundant components in different but similarly constructed buildings on the same basemat are also judged to be correlated. For other components consider zero correlation. Perform preliminary quantification of risk metrics (CDF, LERF). At the second stage, during evaluation of preliminary quantification results, define risk-significant contributors, and focus effort on





evaluation of possible partial correlations for these contributors. Consideration of such factors as exact component location and orientation and spectral frequency sensitivity may be performed. Incorporate adjusted correlations into the probabilistic models and conduct the final quantification with adjusted parameters for correlations. Finally, sensitivity studies for different modelling interpretations of the correlations must be conducted. Possible sensitivity studies include:

- ▶ assume components at risk-significant seismic correlation groups (SCG) as independent;
- ▶ vary correlation coefficients for SCG;
- ▶ introduce a new SCG (e.g., identical components included in different systems, located in different buildings) and consider different correlations for the new SCG (fully correlated, partially correlated).

2.3.2. METIS study case

Seismic PSA study for Zaporizhzhia NPP (ZNPP) Unit 1 was completed (including resolution of regulatory review comments) and approved by State Nuclear Regulatory inspectorate of Ukraine in 2019. Scope of the SPSA include development of Level 1 and Level 2 PSA for two sources of radioactivity – reactor and spent fuel pool. All operational states (POS) are considered in the study: nominal power (POS0), low power (POS1,2,3,4,5,6, 13, 14,15) and shutdown modes (POS7-12), as well as refueling and long-term storage states for SFP. Five earthquake levels (PGA) are modeled:

- ▶ Q1 - 0.085 g
- ▶ Q2 - 0.17 g
- ▶ Q3 - 0.2 g
- ▶ Q4 - 0.3 g
- ▶ Q5 – 1.45 g.

List of ZNPP systems modeled in SPSA includes the following: Emergency core flooding system; low pressure injection system, high pressure injection system, high pressure emergency core cooling system, primary pressure control system, emergency gas evacuation system; ventilation systems; emergency feedwater system; steam dump valves; essential power supply system; essential service water system; containment spray system; SFP cooling system; instrumentation and control, mobile pump system.

ZNPP Unit 1 final seismic equipment list contains more than 1.5 thousand items /ZNPP 2019/:

- ▶ Heat and mass transfer equipment – 653 items;
- ▶ Electric equipment – 111 items;
- ▶ Instrumentation and control – 231 items;
- ▶ Diesel-generator electrical equipment – 152 items;
- ▶ Components not modelled in internal events PSA – 180 items;
- ▶ Pipelines – 498 items;
- ▶ Structures and buildings – 10 items.

The binary approach was used to model seismic correlations. 88 seismic correlation groups (SCG) are defined that represent in total 630 individual components (pumps, tanks, valves, transformers, busbars, electrical cabinets, etc.) Full correlation was assumed for all components within group, based on the following criterion:

- ▶ identical components for a system trains are located in one building at the same elevation.

Special coding scheme was applied for SCG basic events in the PSA model.





According to the quantitative results of /ZNPP 2019/, correlated failures related to PGA more than 0,2 g have significant impact at the total CDF. List of 100 dominant basic events ranked by Fussel-Vesely importance contains 28 SCG events for different PGA values. Moreover, three failures are amongst first ten contributors to the CDF:

- ▶ correlated failures of diesel-generators DG-1 and DG-2 at PGA 0.3g (ranked as 4); Correlated failures of DG-1 and DG-2 at PGA 0.2g, 0.17g are ranked as 34 and 54, respectively
- ▶ correlated failure of nine transformers 0,4 kV of essential power supply system at PGA 0.3g, located at elevation 20.4 (ranked as 8);
- ▶ correlated failure of six busbars 0,4 kV of essential power supply system at PGA 0.3g, located at elevation 20.4 (ranked as 10).

Under METIS study case, these SCG will be assessed in light of possible partial correlations using several methods: beta-factor method, split fraction method, as well method of /NUR 2017/ will be applied to find suitable, more useful solution for seismic PSA practitioners.

Figure 13 - Figure 15 present application of beta-factor method for the abovementioned ZNPP Unit 1 components and show relationships between beta-factor and correlation coefficients, depending on different PGA levels. PGA levels correspond to /ZNPP 2019/. Fragility data are shown in Table 3.

Component	A_m	β_R	β_U
Diesel-generator	1,49	0,30	0,35
Transformer 0,4 kV of essential power supply system	0,964	0,3	0,35
Busbar 0,4 kV of essential power supply system	1,05	0,3	0,35

Table 3: Seismic fragility data for selected components, /ZNPP 2019/.



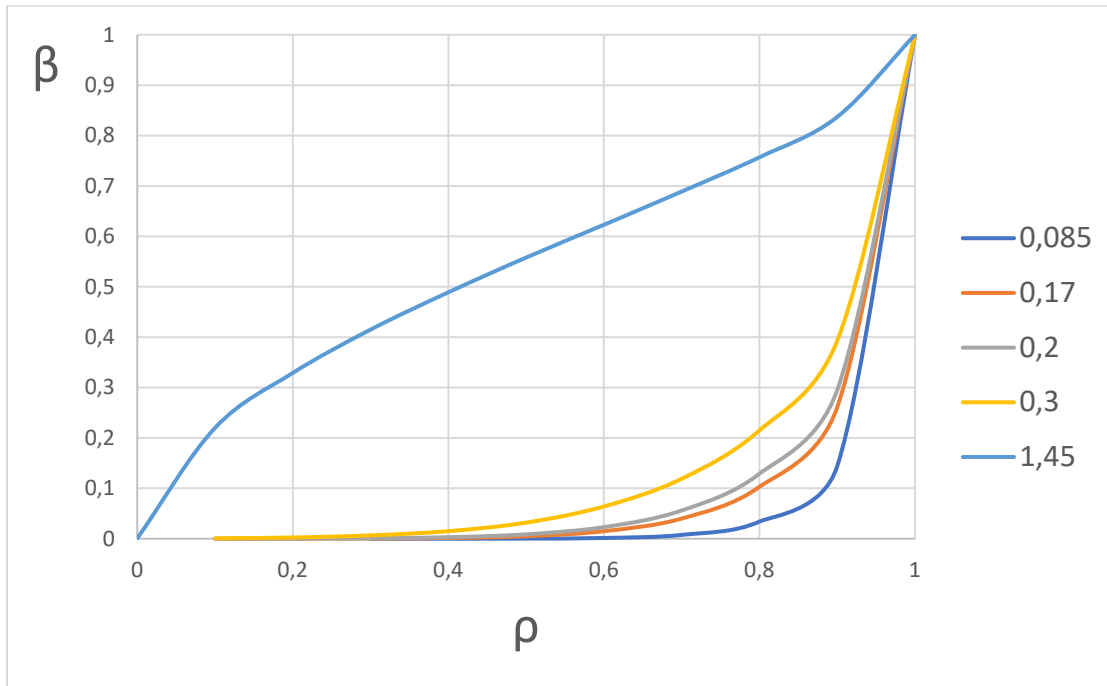

Figure 13: β - ρ curves for SCG with 2 diesel-generators, for different PGAs

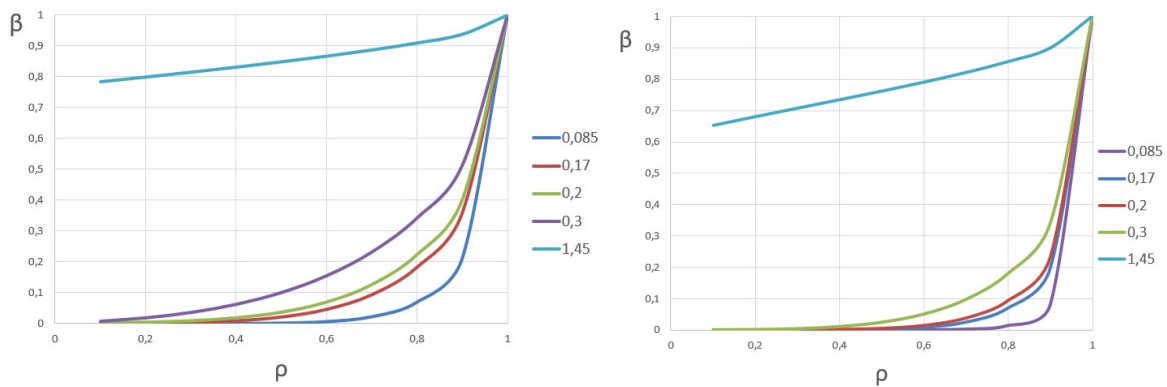

Figure 14: β - ρ curves for transformers 0,4 kV, for different PGAs. Left – 2 members in seismic correlation group, right – 3 members.



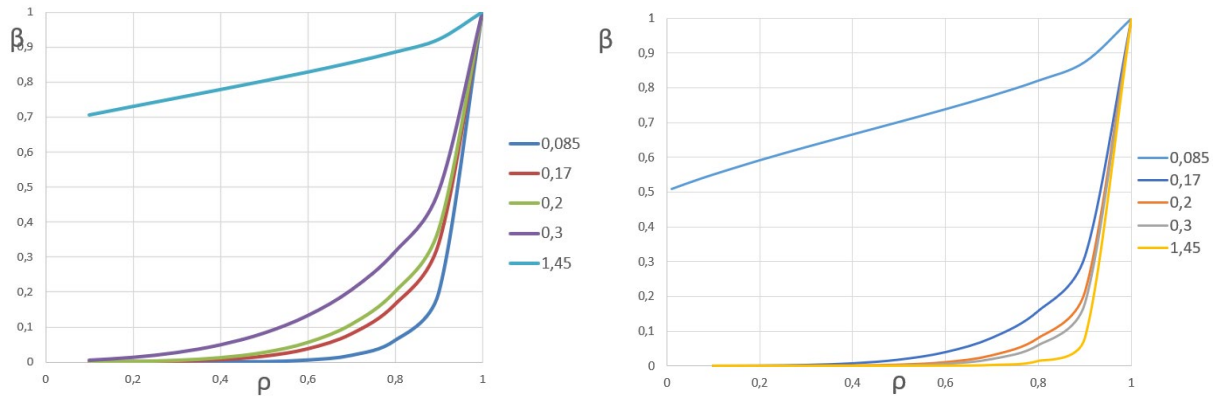

Figure 15: β - ρ curves for 0,4 kV busbars, for different PGAs. Left – 2 members in seismic correlation group, right – 3 members.

Comparison of beta factors for the selected components is shown in Figure 16.

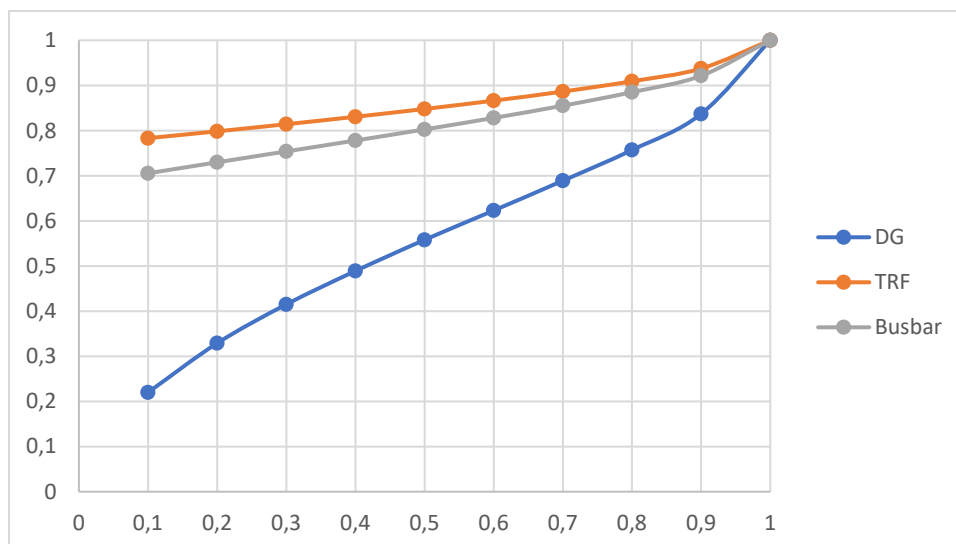

Figure 16: β - ρ curves for ZNPP components for PGA 0,3

3. Multiple units and multiple radiation sources at a site

One of the key modelling issues for seismic PSA of a multi-unit site is the correlation of SSC seismic response between different units. As for single-unit site, the inter-unit correlations arise due to geotechnical characteristics of site, soil structure interaction, seismic ground motion parameters.

Multi-unit (MU) correlations are illustrated at Figure 17, where ρ_{1e} are intra-unit correlations between unit 1 components at elevation e ; and ρ_{2e} - correlations between unit 2 components at elevation e ; ρ_{12} – inter-unit correlations between unit 1 and unit 2 components at different elevations.



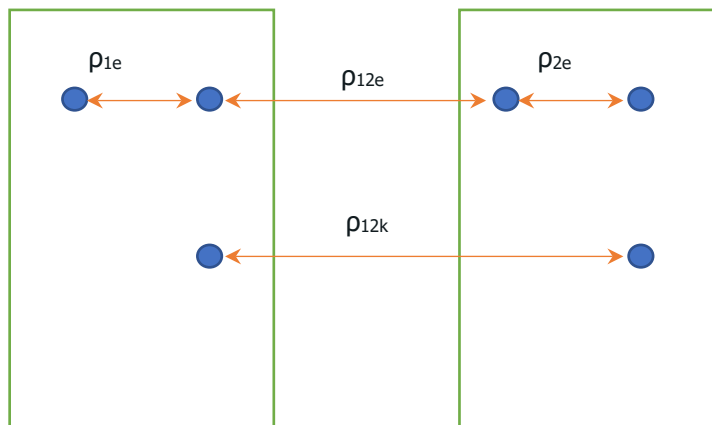

Figure 17: Schematic for intra-unit and inter-unit correlations

As can be seen, there is a difference between single-unit and multi-unit PSA models:

- ▶ Single-unit (SU) models typically consider correlations between redundant components of systems with identical redundant trains
- ▶ Multi-unit (MU) models, in addition to single-unit correlations, should consider the following:
 - correlations between redundant components of the same systems (with identical redundant trains) of several units (ρ_{12e} at Figure 17); and
 - correlations between the risk-significant non-redundant same components of the same systems of several units (ρ_{12k} at Figure 17). It should be noted that assuming complete correlation for many inter-unit seismic failures can be overly conservative for seismic PSA, because the frequency of multi-unit core damage will be close to the single unit CDF; and
 - correlations between seismically induced initiating events at several units (e.g., loss of coolant accidents, internal flooding, etc.).

Correlations above for MU models are applicable to the sites with nuclear units of the same design. The multi-unit issue also includes further complications if units of different designs are present at the site, for example, the Kashiwazaki-Kariwa site in Japan, or Olkiluoto site in Finland with several different designs.

Another difference between SU and MU correlations is illustrated in Figure 18.

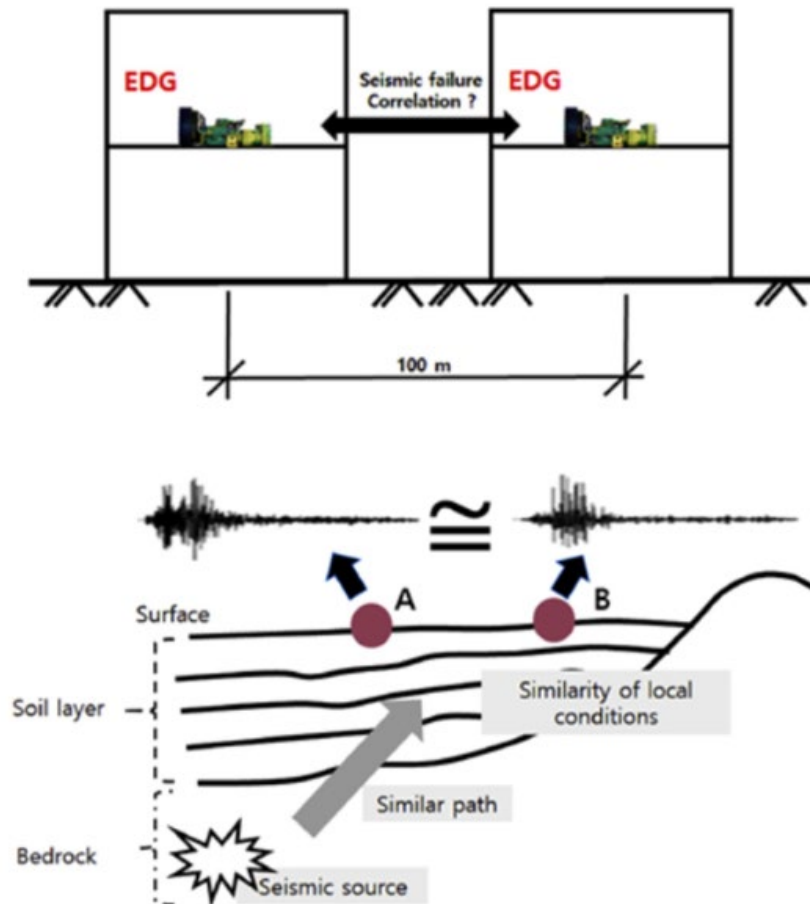

Figure 18: Example of inter-unit correlations

Therefore, in comparison with single-unit PSA, multi-unit configurations increase the importance of correlations. For NPP sites with highly independent nuclear facilities, the MU CDF (frequency per site-year of an accident involving core damage on two or more reactors on a MU site) is very sensitive to the degree of dependency assigned to important SSCs. For such NPPs, a MU CDF is dominated by minimal cut sets containing failures of corresponding components. Correlations like ρ_{12e} , ρ_{12k} between such components may significantly increase CDF. Finally, effects of correlations can significantly influence on the site CDF (total CDF for each unit plus an extra CDF due to MU effects). For NPP sites with many interconnections between units, when dominant contributors to core damage are shared structures or systems, the MU CDF would be less sensitive. That is because the dominant and unchangeable portion of the CDF is governed by shared SSCs.

Regarding the single-unit correlations (intra-unit correlations), recommendations are presented in the Section 2. In general, multi-unit correlations (inter-unit correlations), can be considered using the same approaches. Moreover, several methods listed in Table 1 have been developed with focus on inter-unit correlations (e.g COREX, Hybrid method).

4. Vector valued analyses

As for today, rather standard, seismic PSA practice is to use single intensity measures for both, the fragility model and probabilistic seismic hazard analysis. This can be assumed as adequate for the single-mode-dominant structures. For multiple-mode dominant structures (e.g., a cable-supported structure or bridge) and equipment having multiple failure modes that are governed by different parameters of ground motion, the response could be better predicted using multiple parameters of ground motion. Then, the vector-valued analyses may be judged as more appropriate. However, there are several



reasons, like: extensive computational efforts; small number of available specific codes; the limited number of prediction models for some intensity measure levels; the lack of correlation models between several intensity measures; necessity for extensive consultation of vector-valued aspects from seismologists, which prevent vector-valued SPSA from being ready for practical purposes. Recent reviews of Seismic PSAs (see, e.g. observations in /SMIRT 2022/) have shown that there are no SPSA solely based on (or extensively using) vector-valued analyses.

Vector-valued analyses can be used at different stages of seismic PSA:

- ▶ Vector-valued Probabilistic Seismic Hazard Analysis (VPSHA);
- ▶ Vector-valued fragility analysis for SSCs.

4.1. Probabilistic Seismic Hazard Analysis

Results of scalar probabilistic seismic hazard analysis (PSHA) used in seismic PSA are mean annual frequencies of exceedance for different values of a selected ground motion parameter (typically, PGA). These frequencies are further used as seismic initiating event frequencies – entry point for event trees. Seismic initiating event frequencies can be calculated as:

$$F = \int_{a_1}^{a_2} \frac{dH(a)}{da} F(a) da ,$$

Where a_1 and a_2 define the acceleration range corresponding to a specific seismic event.

Under PSHA, the mean annual frequencies are calculated by equation, see METIS deliverable 4.4. /METIS 2024b/:

$$\lambda(IM > im) = \sum_{s=1}^{n_{sources}} \sum_{r=1}^{n_{ruptures}} v_{s,r} P(IM > im | ruptures_{s,r} ,$$

where $\lambda (IM > im)$ is the annual rate of exceedance of the intensity measure level im , $P (IM > im | ruptures_{r,s})$ is the conditional probability of exceeding the intensity measure level im . $v_{s,r}$ is the rate of occurrence of the rupture r in source s .

Example of scalar (single intensity measure) PSHA results is shown in Figure 19.



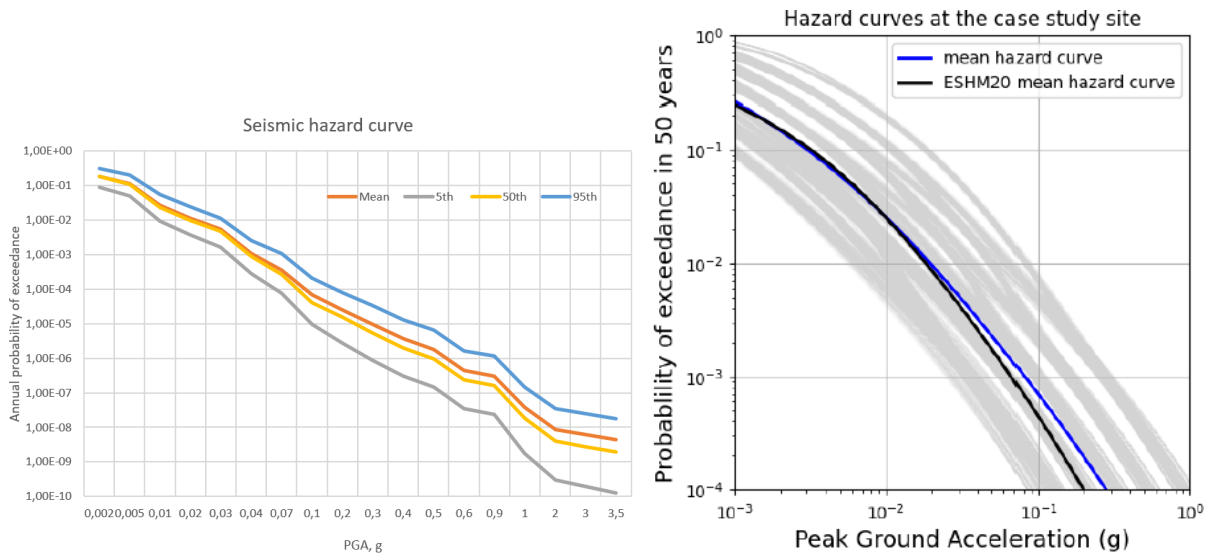

Figure 19: Seismic hazard curve for single IM. Left for PGA from /ZNPP 2019/, right - PGA for the METIS study case /METIS 2020/,

Vector-valued PSHA (VPSHA) have the similar objective – to calculate the mean rate of exceedance, but for a combination of intensity measures. Under VPSHA, the mean annual frequencies can be calculated by equation, see METIS deliverable 4.4 /METIS 2024b/:

$$\lambda(IM_1 = im_1, IM_2 = im_2) = \sum_{s=1}^{n_{sources}} \sum_{r=1}^{n_{ruptures}} v_{s,r} P(IM_1 = im_1, IM_2 = im_2 | rupture_{r,s}),$$

where $P(IM_1 = im_1, IM_2 = im_2 | rupture_{r,s})$ is the discrete joint probability of occurrence of im_1 and im_2 given the occurrence of $rupture_{r,s}$. $P(IM_1 = im_1, IM_2 = im_2 | rupture_{r,s})$ is computed using a multinomial Gaussian distribution.

Example of VSHA results is shown in Figure 26. In this example, as a direct extension of scalar PSHA, the key additional information required in performing VPSHA is the joint conditional probability distribution of spectral accelerations at multiple periods.



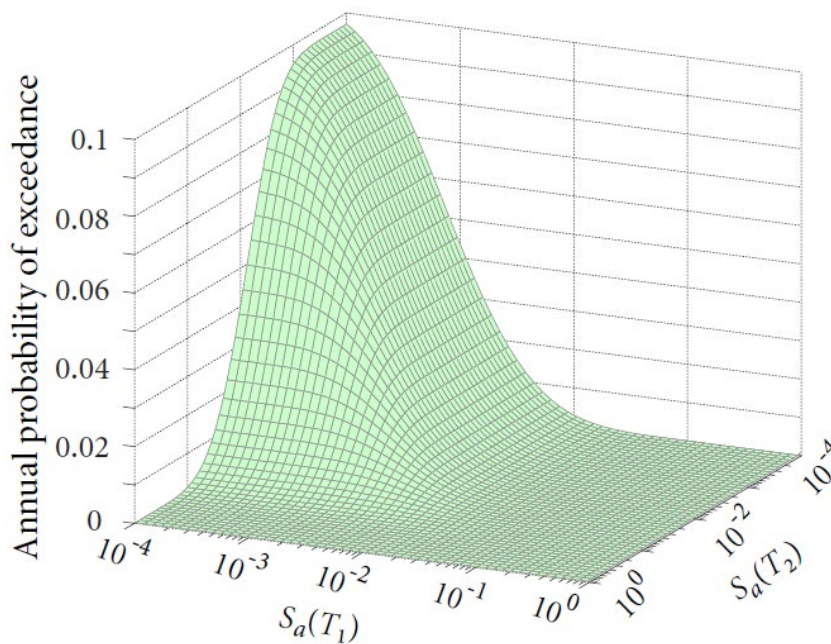

Figure 20: Seismic hazard surface for spectral accelerations at 4.0 sec and 1.33 sec from VPSHA, /Wang 2015/

Different approaches for VPSHA: direct, indirect, simplified, new kernel matrix approach proposed by METIS are discussed in METIS deliverable 4.4. VPSHA provides a more comprehensive description of the different ground motion characteristics (compared to scalar PSHA) required for particular studies such as risk analyses of various typologies of structures or evaluations of the slope stability under seismic excitation. In terms of accuracy, VPSHA can ensure higher level of accuracy than scalar PSHA, (0,4% error for VPSHA and 2,4% error for scalar PSHA) /Wang 2015/. However, according to discussion in the METIS deliverable 5.1 /METIS 2020/, using vector intensity measures comes at a price that is arguably higher in many cases than the benefits obtained by a more accurate prediction of engineering demand parameter. That is why some authors have proposed a well-crafted scalar IM, like average spectral acceleration. In addition, there is a study /EESD 2019/ that showed (based on analysis of 50 IM pairs for six intensity levels and on comparison of the results in terms of mean annual frequency of exceeding specific engineering demand parameter thresholds) as long as the hazard consistency is ensured in both directions, it is not relevant if vector or scalar IMs are utilized because the results obtained, in most cases, are statistically indistinguishable.

Due to several reasons including abovementioned, scalar PSHA was selected to be applied for the METIS study case. Discussion and the results of the scalar PSHA - hazard curves for PGA, S_A (0.2 s), and S_A (1.0 s) at the case study site - are documented in /METIS 2023/).

4.2. Fragility analysis

Currently, rather standard methods, applied for performing seismic fragility analysis for SPSA are based on fragility curves representing the ground motion by a scalar intensity measure. In practice, majority of seismic PSAs have used PGA as single IM. It should be noted, that PGA is used as a simplified measure for the whole uniform hazard response spectrum shape. Also, the structural frequency filtering effects are included in the in-structure response spectra and the frequency sensitivities of SSCs are accounted for in fragilities, to the extent they influence the fragility calculations. All of this is indexed to a PGA hazard for quantification, but the effects of spectral accelerations and frequency sensitivities of SSCs are considered throughout the fragility calculations. . Several studies (e.g., /SMIRT 2015/) have





discussed that the characterization of seismic capacity of a SSC by single IM can never be comprehensive due to the fact that the SSCs are dynamically complicated. Influence of other IM is noticeable and should be taken into consideration. In particular, spectral accelerations at dominant modes of critical SSCs should be chosen as IMs in seismic fragility analysis to improve the plant seismic capacity estimate, /Zhen 2018/. Comprehensive, more accurate, evaluation of fragility parameters, like high confidence of low probability of failure (HCLPF) using vector-valued approach may have influence on calculation of SSC failure probabilities, and even on quantification of human error probabilities (see Table 5). Finally, it may affect on quantification of more realistic results of seismic PSA (core damage frequency, large release frequency).

Several methods are available to perform scalar fragility analysis, the most used in SPSAs are:

- ▶ Conservative deterministic failure margin (CDFM) method. CDFM (also named as hybrid method) is a simplified method for estimating fragility curves, using the CDFM method to establish a HCLPF capacity, and a composite logarithmic standard deviation β_c estimate is used to estimate the mean fragility curve.
- ▶ Separation of variables (SOV) method. The method explicitly characterizes a probability distribution (median value, aleatory variability, and epistemic variability) for each parameter affecting the SSC's response and capacity. The final fragility distribution is obtained from the individual variables using the mathematical properties of lognormal distributions. Typically, the SOV is preferred method for SSCs that are dominant risk contributors or are risk significant in the seismic accident sequences.

There are number of modifications of these two methods (see, e.g. modified CDFM in /SMIRT 2022d/) and modelling techniques applied to compute the fragility parameters, like safety factor technique, linear regression, maximum likelihood estimation, incremental dynamic analysis, Bayesian updating etc.

Seismic fragility is modeled by a lognormal cumulative probability distribution (CDFM), double lognormal model (SOV). General equation for SOV is as follows:

$$A = Am \times e^{(z\beta_R)} \times e^{(z\beta_U)}$$

where: A_m is the median capacity; β_R is the logarithmic standard deviation of the aleatory uncertainty, β_U is the logarithmic standard deviation of the epistemic uncertainty, z is the standard normal variable corresponding to a defined non-exceedance probability. The aleatory and epistemic uncertainty can be combined into a composite variability (β_c):

$$\beta = \beta_c = \sqrt{\beta_R^2 + \beta_U^2}$$

Example of scalar fragility curves calculated for PGA as IM, by using different methods is shown in Figure 21, where conservative nature of CDFM for this example is evident, although this big of a difference is unusual. Example comparison of scalar fragility curves computed for different IM is presented in Figure 22.



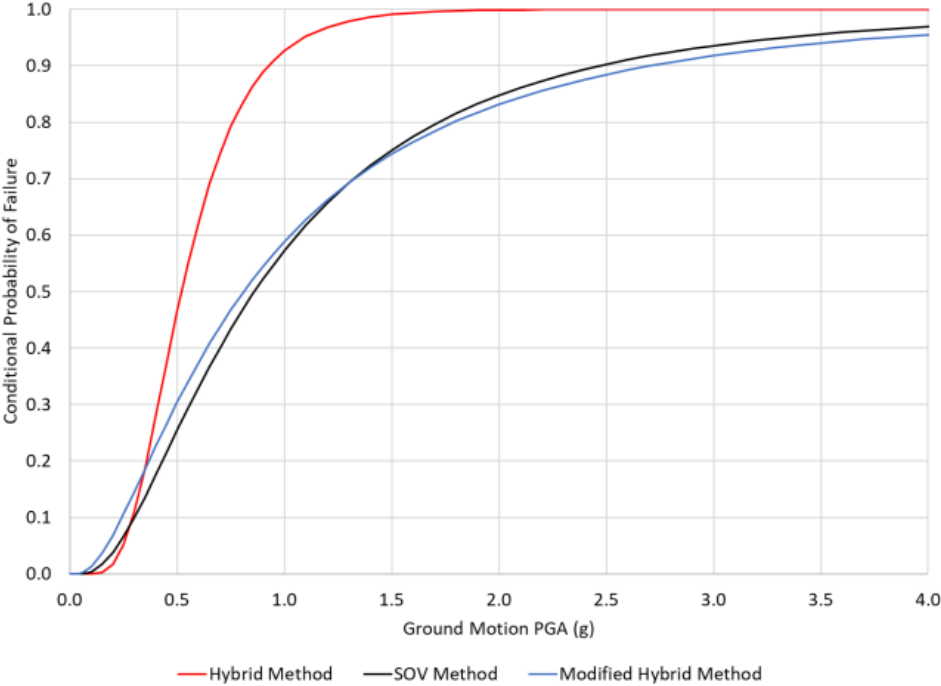

Figure 21: Mean seismic fragility curves obtained by CDFM, SOV and modified CDFM for PGA, for example SSC, /SMIRT 2022d/.



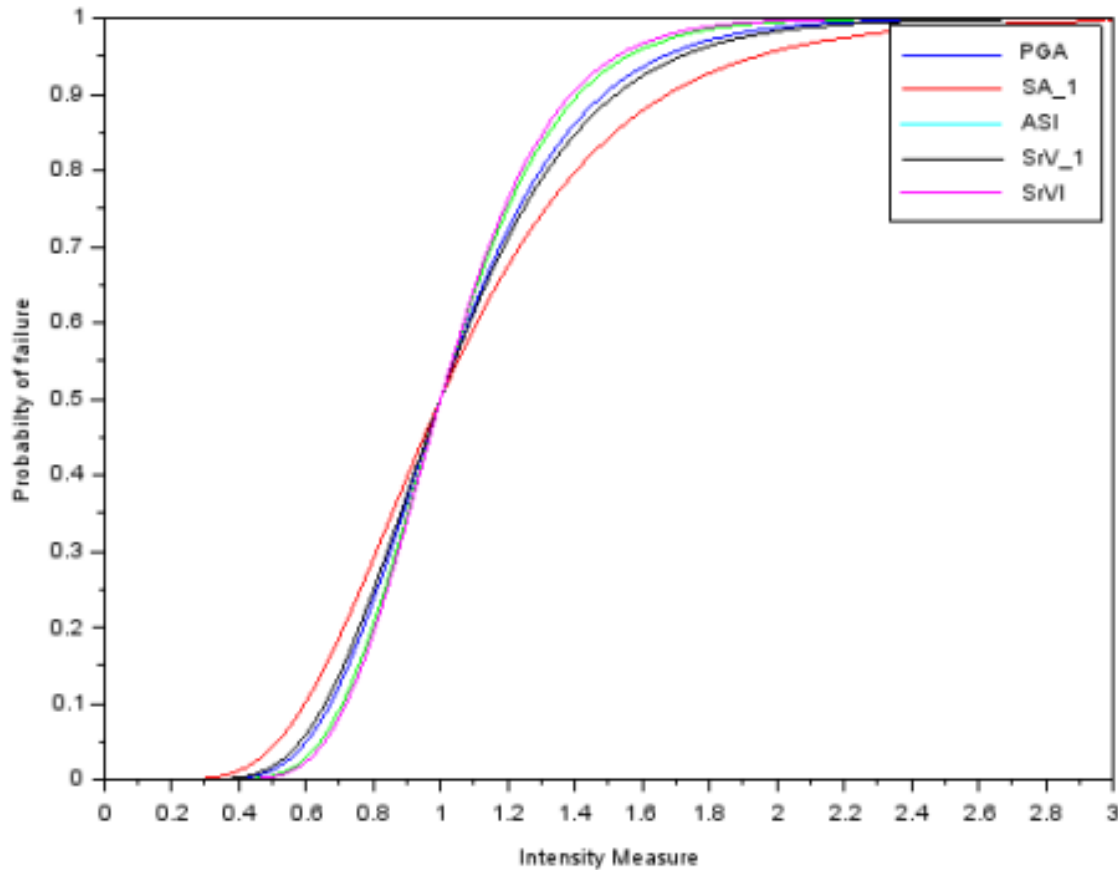

Figure 22: Mean seismic fragility curves computed for different IM (PGA; SA_1: Absolute spectral acceleration at first frequency, f_1 ; ASI: average absolute spectral acceleration in the range $[f_1: f_1+1\text{Hz}]$; SVr_1: relative spectral acceleration at first frequency; SrVI: average relative spectral velocity in the range $[f_1: f_1+1\text{Hz}]$) for example SSC, /NAR 2019/.

Another way to represent scalar fragility analysis is as follows, /NENE 2021/:

$$P_f(im) = P(ds \geq DS | IM = im) = \Phi\left(\frac{\ln im - \ln \alpha}{\beta}\right),$$

where P_f is the probability of failure, α represents the median and β the standard deviation, i.e. the fragility parameters; ds – damage state. The damage state is defined by the engineering demand parameter (EDP) exceeding a given threshold: the EDP represents the physical demand that is subjected to the SSC, until its capacity is reached. By definition, the parameter α is the value of IM for which P_f is 50% and can thus be viewed as the median capacity (in terms of IM).

Vector-valued fragility analysis is described in /GEHL 2012/, where hybrid IM is formulated in terms of two IM1 and IM2 as follows:

$$\log X_i = \frac{\alpha_1}{\alpha_1 + \alpha_2} \log IM1_i + \frac{\alpha_2}{\alpha_1 + \alpha_2} \log IM2_i$$



D7.7 Assessment of new or improved PSA approaches

where α_1 are regression coefficients. Assuming that the univariate fragility function in terms of X is compatible with the lognormal model in equation above for scalar fragility analysis, leads to the following vector-valued fragility function, /NENE 2021/:

$$P(\text{damage} \geq \text{DS} | \text{IM1}, \text{IM2}) = \frac{1}{2} [1 + \text{erf}(\beta_1 \log \text{IM1} + \beta_2 \log \text{IM2} - \beta_0)]$$

The coefficients β can be estimated by maximum likelihood estimation.

It is shown in /GEHL 2012/ that switching from scalar to vector IMs may lead to a significant reduction in the scatter in the fragility function and consequently to potential reduction in the uncertainty in evaluated earthquake risk.

Examples of the results of vector-valued fragility analysis are shown in Figure 23.

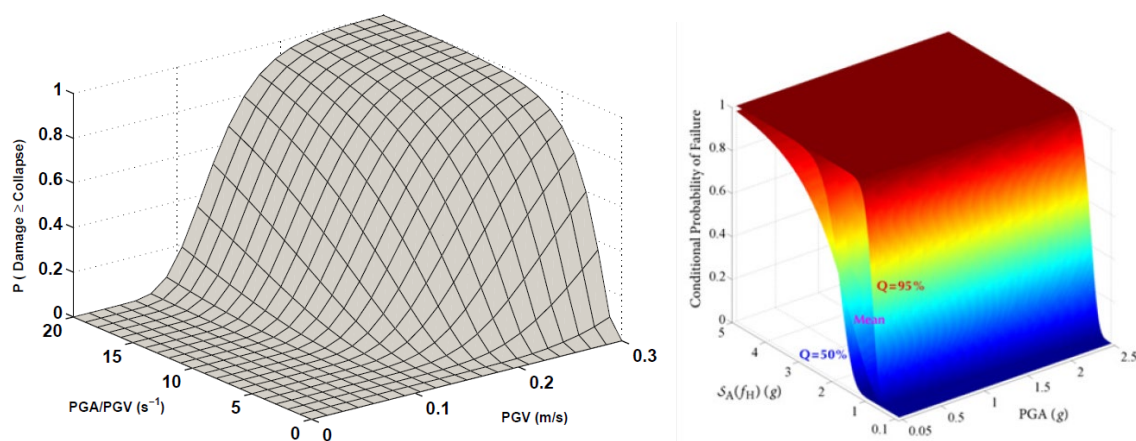

Figure 23: Fragility surface, using the two IM: left – vector $\langle \text{PGV}, \text{PGA/PGV} \rangle$, /Gehl 2012/; right – vector $\langle \text{Sa}, \text{PGA} \rangle$, /Zhen 2018/.

Several studies represent analysis of IM and/or vector IMs in terms of their adequacy for the derivation of fragility curves. Criteria to assess the adequacy in terms of efficiency, sufficiency, practicality, computability, are outlined and summarized in /NAR 2019/.

There are many studies regarding selection of IMs. For example, /ISCU 2015/ states that PGA was not indicated to be an efficient IM for analyzed types of structural systems and types of soil. Peak ground velocity PGV is nominated as a universal IM that could be used instead of the PGA. Also, the use of spectral acceleration $S_a(T1)$, spectral response velocity value $S_v(T1)$ and spectral response displacement value $S_d(T1)$ has given very good results but engineer should bear in mind that their calculation is more complicated because they depend on the dynamic characteristics of the structure. The results of /SDEE 2018/ also indicate that for a displacement-sensitive structure, the peak ground velocity is the most efficient scalar-valued IM, while the $\langle S_a(T1), \text{PGV} \rangle$ is the most efficient vector-valued IM. It was discussed in /NAR 2019/ that the vector-valued intensity measures tend to perform slightly better than the single intensity measures (like PGA). This conclusion is based on evaluation of several criteria. The fragility surface representing ground motion by vector IM $\langle \text{PGA}, \text{PGA/PGV} \rangle$ tends to reduce uncertainties in comparison to the fragility curve representing ground motion only by PGA.

Under the METIS project, detailed selection of relevant ground intensity measures (scalar or vector) to reduce the scatter and epistemic uncertainty of response results, is the aim of Deliverable 6.3. Fragility analyses of relevant SSCs by considering optimal scalar/vector IM are part of Deliverable 6.5. Regarding



the METIS study case, since scalar was selected to be applied (see Section 4.1), the scalar fragilities will be used in the case study.

5. Human performance

5.1. Seismic impact on HRA

Human failure events (HFE) explicitly modelled in seismic PSA model need to be identified and reviewed. According to human reliability analysis (HRA) methodology (see IAEA SSG-3, /IAEA 2024/) three categories of human actions should be considered:

- ▶ Pre-initiator (type A) actions - human actions before the initiating event during normal operation that degrade system availability (e.g., mis-calibrations, misalignments). Such actions do not depend on the characteristics of the later initiating event, thus results of the analysis performed during the internal event PSA remain in effect for seismic PSA. It may be necessary, however, to model Type A actions to supplement for systems that are newly modelled for seismic events. Applied method can be the same as that used in the internal event PSA.
- ▶ Human induced initiating event (type B actions) - not applicable in the case of seismic initiating event
- ▶ Post-initiator (type C) actions. Discussion below deals with Type C human actions.

Scope of human actions does not necessarily change as compared to the internal event PSA. New actions may appear in the case of seismic-specific mitigation strategy. Such actions consist of the following types of actions: terminating the impact of the seismic event – actions taken to identify and protect components that are operating in an undesired state or are threatened after the seismic event has occurred; mitigation of seismic consequences using the affected SSC – actions taken to recover failed SSCs by providing an alternate success path (e.g., restoration of power to an electrical bus by using mobile diesel generator).

Seismic events challenge the availability of human resources from outside plant having an impact on HRA. NPP personnel may be distracted from nuclear safety due to private concerns (rescue, securing homes) reducing their reliability. Unclear priorities for overall emergency response by local authorities may be in conflict with the priorities for SAMG. The availability of rescue and support from outside the plant (e.g., fire brigades, medical aid, and heavy machines for clean-up operations) may be limited due to the simultaneous needs of civil protection outside the plant.

In general, the following seismic related factors on human actions (seismic factors) should be considered during re-evaluation of human error probabilities:

- A. Mental and physiological stress induced by earthquake;
- B. Additional workload (above that for similar sequences not caused by seismic events);
- C. Uncertainties in event progression (e.g. cue availability, timing concerns, failure of signals, spurious signals, failure of communication systems);
- D. Effect of seismic failures on mitigation and on response actions and recovery activities (e.g. accessibility restrictions, possibility of physical harm, equipment approachability - local operator actions might no longer be possible, manual action might not be possible due to failure of specific components);
- E. Specific operator action aids and training (e.g. procedures, training exercises);





D7.7 Assessment of new or improved PSA approaches

F. Increasing chance for errors of commission - human failure event resulting from a well-intended but inappropriate, overt action that, when taken, leads to a change in the plant and results in a degraded plant state (e.g. intentional isolation of the Isolation Condenser system at Fukushima Dai-ichi as per operation manual).

G. Fire and/or flood caused by earthquake;

There are, however, HRA technology challenges defined in /PSAM 2013/, /APSA 2015/ that should be considered during HRA for seismic PSA. The challenges include:

- ▶ Treatment of different or multiple decision makers, including external distractions. The issue is related to accounting for different decision makers (i.e., rather than a typical control room crew) who made potential errors in the prioritization of work (possibly due to incorrect information regarding the system and plant status or input from external organizations).
- ▶ Treatment of the psychological impact on operators, experts, and decision makers;
- ▶ Treatment of the feedback from offsite consequences to plant decision making;
- ▶ Assessment of cumulative effects (e.g., fatigue, radiation exposure) on operators.

Several approaches to quantify seismic human error probability (HEP) are available. Widely used approach is application of existing HRA methods used in level 1 internal event PSA. In this case, HRA process for human error probability usually includes the following steps:

1. Identification of human failure events (HFE) including HFEs already modelled in the internal events PSA and new HFEs related to the seismic events with the specification of the location of the action (in the control room, at local compartments, at the NPP site. Review of human actions from the internal events PSA is performed to identify the post-initiator operator actions modelled. The operator actions that are identified to be part of the internal event PSA and that have been retained in the seismic probabilistic models (fault trees/event trees) are examined to determine the effect of seismic events on their quantification.

2. Characterization of the time available to perform each identified post-initiator action. During a seismic event, the operator faces a challenging situation due to mentioned above seismic factors (additional stress caused by the earthquake itself, accidental damage to systems and components, possible blocking of the accident response route, possible induced fires and floods, aftershocks, and the likely disruption of communications and control time available for diagnosis and execution, can also be smaller than for internal events.

3. Quantification of the post-initiator HEPs. Depending on nature of HFE (existing in internal events PSA, seismic-specific HFE), quantification is performed in slightly different ways: for existing actions, the seismic HEPs are obtained by multiplying the HEPs calculated as for internal events PSA with the performance shaping factors (multipliers). The factors necessary for developing a multiplier are: the location of the task (inside or outside the main control room), the time available for the task, and the seismic intensity. For new HFE calculation of HEPs is performed from scratch, applying HRA method from internal events PSA or HRA method that is judged to be most suitable for seismic PSA. According to the modern practice (see, example on /NEAT 2021a/), it is acceptable to use several HRA methods within one PSA study, depending on nature of human action (cognitive action, executive action, procedural/non-procedural, immediate/long-term, etc.) and capabilities of HRA method. Some recommendations are included in the Table 4.

4. Model integration - modelling of basic events that represent HFE in probabilistic models (fault trees/event trees), see the METIS tool illustration in Figure 24.



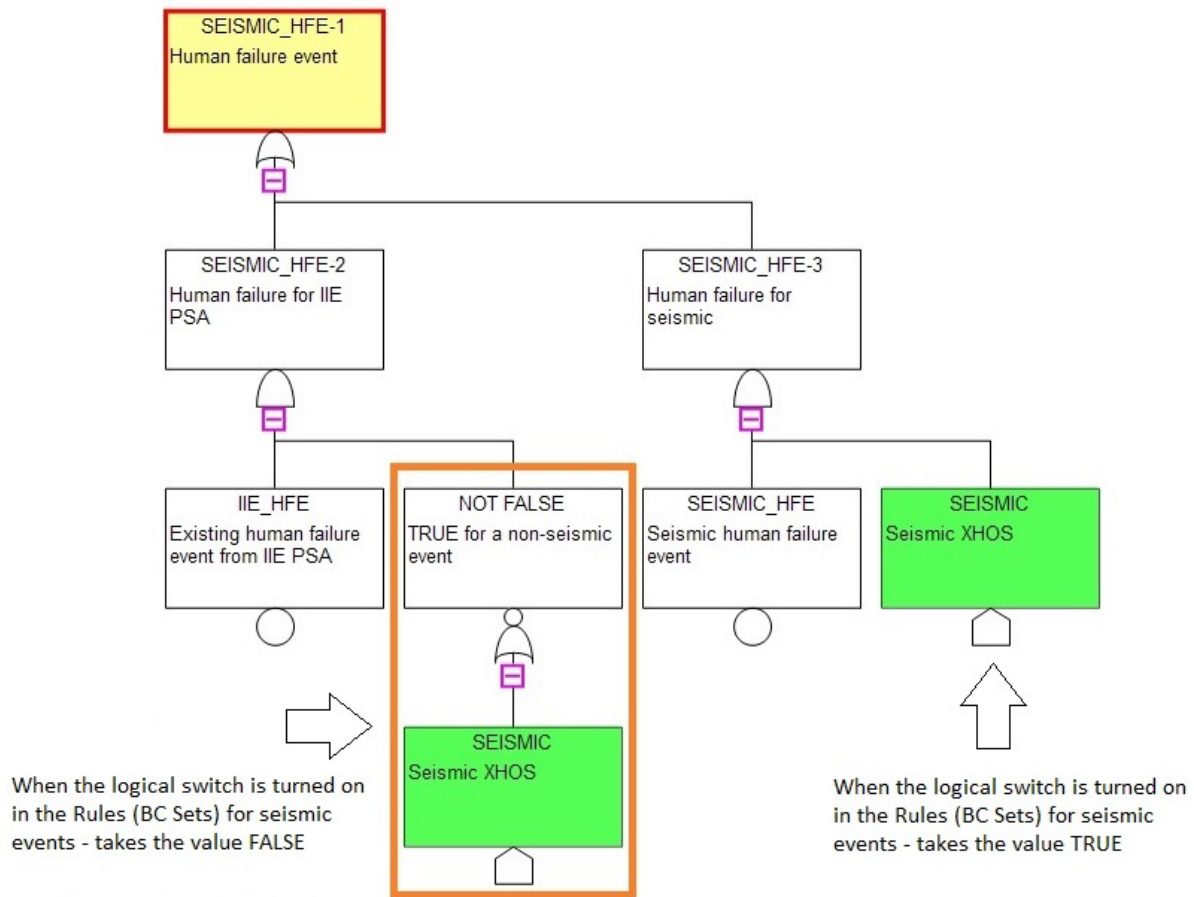

Figure 24: Way to model HFE in a fault tree

Using the existing (in the internal events PSA) HRA approach and associated event trees and fault trees from the internal events analysis with appropriate modifications for the seismic event has the following advantages: this approach supports overall consistency of modelling nomenclature and level of detail and compatibility of results and their interpretation. This allows appropriate non-seismic component failures and non-seismic human errors used in the internal events PSA to be carried through to the seismic PSA where seismic-related failure considerations can be incorporated. The sources of data and bases for use for non-seismic failures should be available from the internal events PSA.

There are over 60 HRA methods that have been developed for different applications. Depending on intended application, HRA methods have been evolved and refined. Illustration of the history of HRA methods is shown in Figure 25



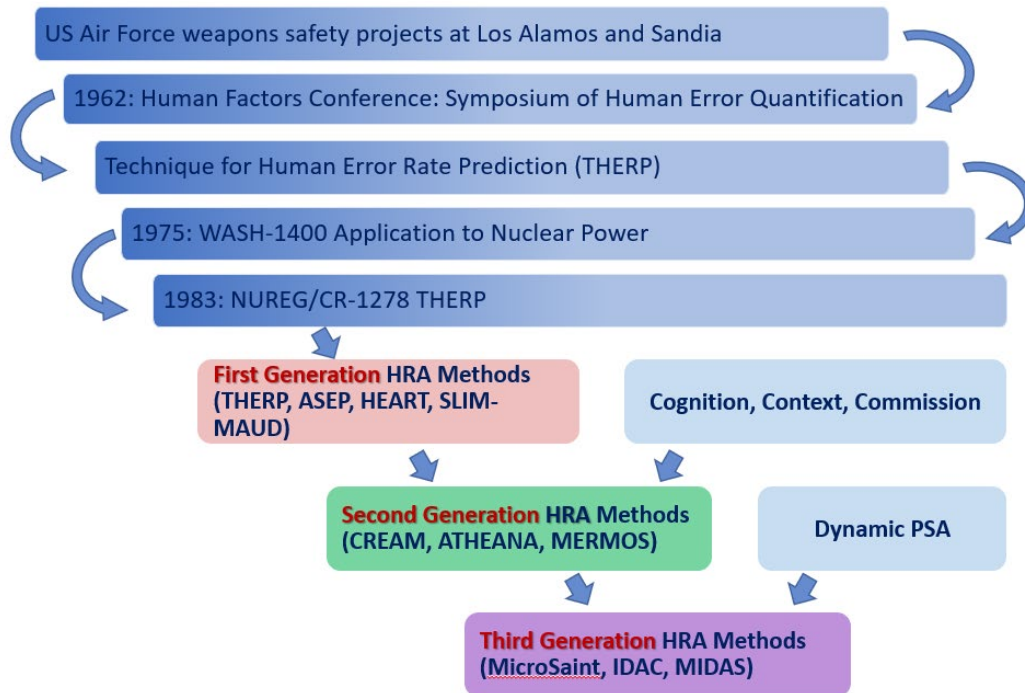

Figure 25: Evolution of HRA methods

Although several limitations of the first-generation methods in error identification and error probability quantification have been widely discussed (e.g., the methods were insufficiently structured to prevent significant analyst-to-analyst variability of the results generated; the methods lacked procedures for identifying the most risk-significant category of human error, errors of commission, etc.), these methods (mainly THERP, ASEP) are still widely used in the NPP industry. Moreover, de facto THERP/ASEP is a standard method incorporated in several commercial codes (EPRI HRA calculator, RiskSpectrum HRA). According to /INAC 2017/ wide use of the first-generation methods occurs because it is more concentrated to calculate the probability of success or failure in the execution phase of human interaction, or human action, what makes them useful for quantitative risk assessment to PSA. The second-generation methods have capabilities to identify errors of commission, context or cognition. These methods (ATHEANA, CREAM) are so complex that still have some obstacles to be applied in a conventional HRA. Table 4 provides some overview of available HRA methods and comments regarding seismic PSA. The comments have been prepared from data provided in several sources, such as NUREG - 1842 /NUR 2006/.

Method	Approach for Quantification	Comments
<p>THERP - Technique for Human Error Rate Prediction, see NUREG/CR-1278 /NUR 1983/.</p> <p>Primarily modeled such aspects as missing a step in procedure, reading a wrong indication, selecting a wrong switch, etc</p>	<p>Model-based approach. The method is based on data gathered from reactor control room, weapons manufacturing, and chemical processing activities, as well as expert estimation.</p>	<p>Most widely used HRA method is combination of THERP/ASEP. For seismic PSA the THERP algorithm for control actions is recommended for quantification of executive actions (executive portion of HEP).</p> <p><i>Strengths</i></p> <p>Has a five level dependence model for across subtask dependence, and although explicit guidance is not provided, it can reasonably be generalized to address dependence across human actions in a PSA sequence.</p>





Method	Approach for Quantification	Comments
	<p>Provides tabulated or time-reliability based human failure estimates.</p> <p>Is considered as complete method because it addresses both qualitative and quantitative analysis. Many HRA methods only address quantification.</p>	<p><i>Limitations</i></p> <p>Although this method provides good discussion of a broad set of PSFs, it explicitly uses only a limited set in its tables and curves and does not provide much guidance for how to handle a wider set of potentially important factors. The lack of guidance increases the potential for analyst to analyst variability in results when a broader range of factors is considered.</p> <p>Regarding the seismic factors – THERP is not capable to deal with increasing chance for errors of commission</p>
<p>Accident Sequence Evaluation Program HRA Procedure (ASEP), see NUREG/CR-4772 /NUR 1987a/ use a more explicit process suitable for non-HRA experts and reduces the number of factors to be considered</p>	<p>Provides tabulated or time-reliability based failure estimates</p>	<p>ASEP developed as simplified version of THERP.</p> <p><i>Strengths</i></p> <ul style="list-style-type: none"> • Easy to use, simplified technique • Results commonly accepted as reasonable for “not far from average” context (i.e., conditions associated with the scenario and action of interest). • Since analysis is simplified relative to THERP and values to be applied are stated to not account for possible positive considerations, results are argued to be more conservative than those obtained with THERP. • Extends THERP in several respects, particularly in the treatment of pre-initiators. • Screening approach requires some consideration of influencing factors as opposed to simply assigning a “high” value. • Provides a reasonable, simplified version of the THERP dependence model (but THERP is still recommended when generalizing to address dependence across actions in a PSA sequence). <p><i>Limitations</i></p> <ul style="list-style-type: none"> • It is not clear that the results produced by ASEP would be consistently conservative as claimed (because of a failure to consider other PSFs that may be important drivers).
<p>Success Likelihood Index Methodology & Multi-Attribute Utility Decomposition (SLIM-MAUD) (see NUREG/CR-1278</p>	<p>Expert judgment along with a mathematical formula for</p>	<p><i>Strengths</i></p> <ul style="list-style-type: none"> • The method allows consideration of a wide range of PSFs and is flexible in terms of which





Method	Approach for Quantification	Comments
<p>/NUR 1984/) - provides a calculation process to estimate the overall likelihood of an error based on a range of user-identified performance shaping factors. In principle can be applied to any type of error. MAUD provides additional tools for comparing the effects of different performance shaping factors</p>	<p>combining judgments</p>	<p>PSFs are included.</p> <ul style="list-style-type: none"> • Use of a mathematical formula provides a traceable derivation of the obtained HEPs, as long as the basis for the weights and ratings of PSFs is thoroughly documented. • Use of expert judgements lends credence to the results, provided that the experts are qualified and familiar with the events being assessed. <p><i>Limitations</i></p> <ul style="list-style-type: none"> • Identifying appropriate calibration data is an important issue for this method. • Undesired effects from multiplying and summing PSFs may distort the results (e.g., strong influences may get averaged out).
<p>Systematic Human Action Reliability Procedure (SHARP), see /EPRI 1984/ - frameworks for performing HRA, but not quantification tools</p>	<p>No explicit quantification process, but methods available at the time were discussed</p>	<p><i>Strengths</i></p> <ul style="list-style-type: none"> • SHARP is perhaps the best guidance document available for performing the “overall” HRA analysis. However, a few more recent HRA methods address some aspects not previously addressed or covered in as much detail. • Although it does not provide a quantification process, it leads analysts to identify and consider important information relevant to quantifying modeled human actions. • Very good discussion of dependency issues. <p><i>Limitations for seismic PSA</i></p> <ul style="list-style-type: none"> • Although the potential importance of mistake based errors of commission (EOCs) is noted, the method provides very limited guidance on considering EOCs. <p>SHARP framework is adopted further to consider seismic events in /EPRI 2016/</p>
<p>Human Error Assessment and Reduction Technique (HEART), see /IEEE 1988/) - provides a generic set of descriptions of types of tasks and factors that influence the overall probability of failure</p>	<p>Tabulated data mathematically combined to reflect the type of task and PSFs</p>	<p><i>Strengths (see /Hump 1995/)</i></p> <ul style="list-style-type: none"> • HEART is very quick and straightforward to use and also has a small demand for resource usage • It is highly flexible and applicable in a wide range of areas which contributes to the popularity of its use <p><i>Limitations (see /Kirw 1994/)</i></p> <ul style="list-style-type: none"> • HEART relies to a high extent on expert opinion, first in the point probabilities of human





Method	Approach for Quantification	Comments
		<p>error, and also in the assessed proportion of PSF effect. The final HEPs are therefore sensitive to both optimistic and pessimistic assessors</p> <ul style="list-style-type: none"> The interdependence of PSFs is not modelled in this methodology, with the HEPs being multiplied directly. This assumption of independence does not necessarily hold in a real situation.
<p>Human Cognitive Reliability (HCR) / Operator Reliability Experiments (ORE), see EPRI NP-6937. Vol. 1. /EPRI 1990/) – revision of HCR that provides estimates of failure (non-response probability) based on simulator data or expert judgment and assumptions regarding applicability of normal distribution</p>	<p>Ideally derives time-reliability based estimates from plant specific simulator exercises, but may use expert judgment to obtain time-reliability parameters</p>	<p>For seismic PSA the HCR/ORE algorithms are recommended for quantification of identification, detection and decision making actions (cognitive portion of HEP). HCR/ORE is recommended for post-reactor trip immediate actions (e.g., manual reactor trip), for post-initiator time critical actions (e.g., establish seal injection within 13 minutes), for non proceduralized actions (e.g., recovery actions).</p> <p><i>Strengths</i></p> <ul style="list-style-type: none"> Simplicity of estimation process The use of empirical data to support HRA is a strength. Once the relevant parameters have been identified, the derivation of the HEP using the time/reliability correlation (TRC) is straightforward and traceable. Good discussion on modelling the execution portion of HFE. <p><i>Limitations</i></p> <ul style="list-style-type: none"> It is questionable whether the method can consistently yield appropriate relative values of HEPs and, hence, appropriate safety insights and improvements. Thus, it may require augmented analysis (e.g., with CBDT, ATHEANA).
<p>Cause-Based Decision Tree (CBDT), see EPRI TR-100259 /EPRI 1992b/) – a follow-on to HCR and HCR/ORE, allows the estimate of error probabilities for conditions involving longer time scales and considers causes of errors as opposed to time-reliability relationships</p>	<p>“Tabulated” failure estimates through application of decision trees</p>	<p>CBDT was developed for cognitive errors (e.g., diagnosis) for which time was not a driving influence on performance. For seismic PSA the CBDT algorithm is recommended for quantification of identification, detection and decision making actions (cognitive portion of HEP). The method is recommended for post-initiator proceduralized actions (e.g., isolate ruptured SG in case of steam line break).</p> <p><i>Strengths</i></p> <ul style="list-style-type: none"> Use of a causal model helps analysts to





Method	Approach for Quantification	Comments
		<p>explicitly identify and evaluate conditions that are important in the scenarios examined.</p> <ul style="list-style-type: none"> • Simplicity of estimation process • Provides an initial set of failure mechanisms and influencing factors to be considered, as represented by the decision trees and the factors expected to contribute to the various failure mechanisms, that can be used in a fixed way. <p><i>Limitations</i></p> <ul style="list-style-type: none"> • The method relies on THERP data (which has a limited empirical basis), and through expert judgment adapts it for use in the decision trees. Although the results seem reasonable, the appropriateness of the adapted data for use in the context of the decision trees needs further demonstration.
<p>Cognitive reliability and error analysis method (CREAM), /Holl 1998/) – estimates relative likelihoods of failure based on overall representations of contexts including consideration of workplace, task and organizational factors</p>	<p>Provides tabulated failure estimates</p>	<p>CREAM was developed to better account for cognition. For seismic PSA the CREAM is recommended for quantification of identification, detection and decision making actions (cognitive portion of HEP).</p>
<p>Method d’Evaluation de la Realisation des Missions Operateur la Surete (MERMOS), /Bied 1998/) – provides a way of modelling errors in the integrated human team-computer environments in advanced control rooms using observations of errors in simulator exercises</p>	<p>Expert judgment primarily, but may use some plant data (simulator or operational) as one basis for the estimation process</p>	<p>Developed for internal events, capability of the method to account for seismic factors is questionable</p>
<p>A Technique for Human Event Analysis (ATHEANA), NUREG-1624, /NUR 2000/. ATHEANA provides a structure for understanding and improving human performance in operational events.</p>	<p>Cognitive actions are evaluated by facilitator-led expert judgment process to directly quantify on the basis of context and triggered PSFs. Executive actions are</p>	<p>ATHEANA was originally developed in attempt to address errors of commission during low power/shutdown. Discussion of some seismic factors is included.</p> <p>For seismic PSA the method is recommended for quantification of identification, detection and decision making actions (cognitive portion of HEP).</p> <p>Specifically addresses EOC.</p>





Method	Approach for Quantification	Comments
	included as part of the overall human action in deriving expert judgment-based HEP.	Since executive portion of HEP is not explicitly treated, the method may not be feasible to deal with re-evaluation of complex HFE with several executive actions.
Standard Plant Analysis Risk HRA (SPAR-H), see NUREG/CR-6883 /NUR 2005/ similar to THERP, includes slips, lapses, and mistakes and addresses diagnosis and response execution through use of several PSFs as multipliers. Not intended for detailed analysis of decision-making	Provides tabulated failure estimates	<p>SPAR-H has been developed to create THERP method suitable for Accident Sequence Precursor and Significance Determination Process. The method is not intended for detailed analysis of decision-making.</p> <p><i>Strengths</i></p> <ul style="list-style-type: none"> • Simple underlying model makes SPAR-H relatively simple to use and results are traceable. • THERP like dependence model can be used to address both subtask and event sequence dependence. <p><i>Limitations</i></p> <ul style="list-style-type: none"> • Resolution of the PSFs may be inadequate for detailed analysis. • Despite detailed discussion of potential interaction effects between PSFs, treats PSFs as independent. • No explicit guidance is provided for addressing a wider range of PSFs when needed, but does encourage analysts to use more recent context developing methods if more detail is needed for their application, particularly as related to diagnosis errors.
Phoenix is an HRA methodology that is based on the Information, Decision and Action in a Crew context (IDAC) cognitive model to model operator performance, see "The impact of seismic events on human reliability and Phoenix HRA methodology" /ESR 2023/ and "A model-based Human Reliability Analysis methodology" /RESS 2016/ and /RESS 2024a//Kirw 1994/.	Model based approach	<p>It incorporates strong elements of existing HRA methods and cognitive science, and was initially developed for internal events performed in a control room. Yet, its framework and elements are suitable for external events such as earthquakes.</p> <p>One principal method for incorporating seismic events into an HRA involves multiplying the HEP with a numerical multiplier that is based on one or more factors present in a seismic event.</p> <p><i>Strengths</i></p> <p>A core feature of the Phoenix methodology is its use of Bayesian Networks (BBNs) to model performance influencing factors (PIFs) and their effects on failure modes. This approach allows</p>





Method	Approach for Quantification	Comments
		<p>for a more nuanced understanding of how various factors contribute to human error</p> <p>The methodology emphasizes the importance of how to map data to BBN parameters and aggregate data from non-homogeneous sources</p> <p>The techniques and processes developed in the Phoenix methodology can be adapted for use in other HRA methods and applications, highlighting its potential impact beyond its immediate context</p> <p><i>Limitations</i></p> <p>Despite the advantages of BBNs, the methodology acknowledges the challenges associated with the large amounts of data required for effective modelling. To overcome this, the Phoenix methodology combines multiple data sources, including insights from other HRA methods, expert judgment, and operational experience.</p>
<p>An Integrated Human Event Analysis System (IDHEAS) for Nuclear Power Plant Internal Events At-Power Application, see NUREG-2199 /NUR 2017a/.</p> <p>IDHEAS consists of a qualitative analysis process that includes a detailed cognitive task analysis and an HEP quantification model for HFEs that are identified for inclusion in a PSA and defined at a functional level.</p>	<p>Expert judgement approach.</p>	<p>The quantification model was developed specifically for internal events at nominal power. IDHEAS includes, however, consideration of such variability and uncertainty factors that modulate the time required, as seismic.</p>

Table 4: HRA methods

5.2. Seismic HRA

As discussed above, the standard HRA method used in the internal events PSA must be revised to address the effects of earthquakes on operator performance. Two approaches can be applied:

- (1) A model in which seismic HEP is independent of the level of ground motion. Under this approach, HEPs for the same HFE for all seismic intervals would be the same. Seismic PSA study for ZNPP Unit 1 utilizes this approach, /ZNPP 2019/.
- (2) A model in which HEP during an earthquake depends on the PGA.





The second approach allows more detailed, more precise modelling of seismic impact on human behaviour, and ensures consistency with seismic fragilities of SSC. Also, strong seismic motion can lead to an increased probability of post-initiator errors because of the physiological and psychological effects of seismic acceleration on the cognitive behavior of the operators, characterized by a delay in making diagnosis, formulating response and taking executive action, /KOV 2014/. It should be noted, however, that HRA impact is thought to decrease with increasing intensity of the earthquake. Therefore, this approach seems more adequate for realistic modelling of seismic PSA, and should be used in the METIS study case.

Seismic factor D (e.g. accessibility restrictions, possibility of physical harm, equipment approachability) may have significant impact on HFE – more severe damages of SSC can present unique challenges to operators. Depending on ground motion magnitude (and associated failures of SSCs), damage states for HRA are defined (see, e.g. /EPRI 2016/, /PSAM 2018/, /ESR 2023/). The combinations of the environmental conditions and the types and number of SSC failures create a context for the operator actions modelled. In principal, these damage states differ from seismic hazard bins in that they define break points at which the underlying context of action changes significantly enough to affect the reliability of operator action. The HRA damage states (HDS) are defined by grouping SSCs by their level of expected impact on human performance if they fail (see description of seismic factors). Several levels of the probabilistic modelling of impact are possible: inability of action - depending on HDS, the plant staff has insufficient conditions for performing their task – directly accounted in fault trees/event trees; if the plant staff tasks are feasible, a probability of insufficient workplace conditions due to seismic damage (e.g., instrumentation is damaged and does not provide information to the operator) is modeled in fault trees; while indirect impact of seismic events is modeled through increasing HEP by consideration of associated performance shaping factors according to applied HRA method. Table 5 represents typical considerations for HDS.

#	HDS description	Comment	Typical range of PGA
1	No damage to the plant safety-related SSCs or non-safety SSCs required for operation. Limited damage to non-safety, non-seismic designed SSCs like residences and office buildings	Safe-shutdown earthquake (SSE). Stress level of MCR crew is similar to internal events.	0,085g for /ZNPP 2019/
2	No expected damage to the plant safety related SSCs or to rugged industrial type non-safety SSCs required for operation. Damage may be expected to non-safety SSCs not important to plant operations and to the switchyard. Some falling of suspended ceiling panels.	From SSE to design basis earthquake (DBE). High stress level in early phase due to psychological shocks. Effect of shock lowered after a couple of hours.	At or above the SSE, up to HCLPF of most fragile safety-related SSC. SSE-0,25g at /EPRI 2016/. SSE-Less than 0,3g at /PSAM 2018/ 0.17 g for /ZNPP 2019/
3	Widespread damage to non-safety related SSCs and/or some damage expected to safety related SSCs. Significant number of vibration trips and alarms requiring resetting.	Higher initial stress level than at damage state 2.	Above the HCLPF of most fragile safety-related SSC to HCLPF of critical instrumentation or HCLPF level of 25th percentile component, whichever is lower - 0,25-0,5g at /EPRI 2016/; 0,3-0,7 at /PSAM 2018/





#	HDS description	Comment	Typical range of PGA
			0,3g for /ZNPP 2019/
4	Substantial damage to safety related and non-safety SSCs. The threshold of this damage state is such that it produces a cliff-edge effect in the likelihood of operator response.	Extreme stress level.	Wide-spread damage to critical instrumentation. Any PGA that exceeds PGA for HDS 3. 1,47g for /ZNPP 2019/

Table 5: HDS recommendations

These HDS should be further applied for modelling of human actions (if any) at the METIS study case. At least, it should be used for definition of multipliers during re-evaluation of HFE. During the definition of multipliers, the following aspects are considered:

- ▶ HRA damage state. For HDS 1, 2, and 3 the HEP multipliers for the HFE are 2, 10, and 30 respectively, while for HDS 4 complete failure of human action (HEP=1) is assumed;
- ▶ Time margin . Time margin is a difference between time needed for operator to perform an action (both for cognition - identification, diagnosis, decision making and execution), and time when the action is no longer valuable. The following intervals are considered: less than 10 min; from 10 to 30 minutes, 30 to 60 minutes, and more than 60 minutes. The question is whether the time window is sufficient for proper fulfilment of human action. For time bin 1, complete failure of human action is assumed for all HDS. Sufficient time margin (HEP would be small enough, 1E-04 according for lower bound of ASEP time-reliability curve) is more than 30 min for HDS 1. For HDS 2 and HDS 3 sufficient time margin is assumed as more than 60 min.;
- ▶ Location of action: main control room (reserve control room), at field or outside main control room;
- ▶ Cues (annunciators, indications of indicators, environmental state) to make personnel detect the occurrence of an event, possibility of checking, etc. The intent of this aspect is to identify whether the operator action will be performed with awareness of the post-earthquake plant situation. It may be either available or non-available. The operator may have two types of cues that indicate the demand for action. One is a procedure step, and the other is the alarm. If the cues are alarms, the system for alarms can be damaged by a seismic event. Therefore, it is assumed that alarms in HDS 3 and 4 are not available.

General scheme for calculation of the multipliers is shown in Figure 26.



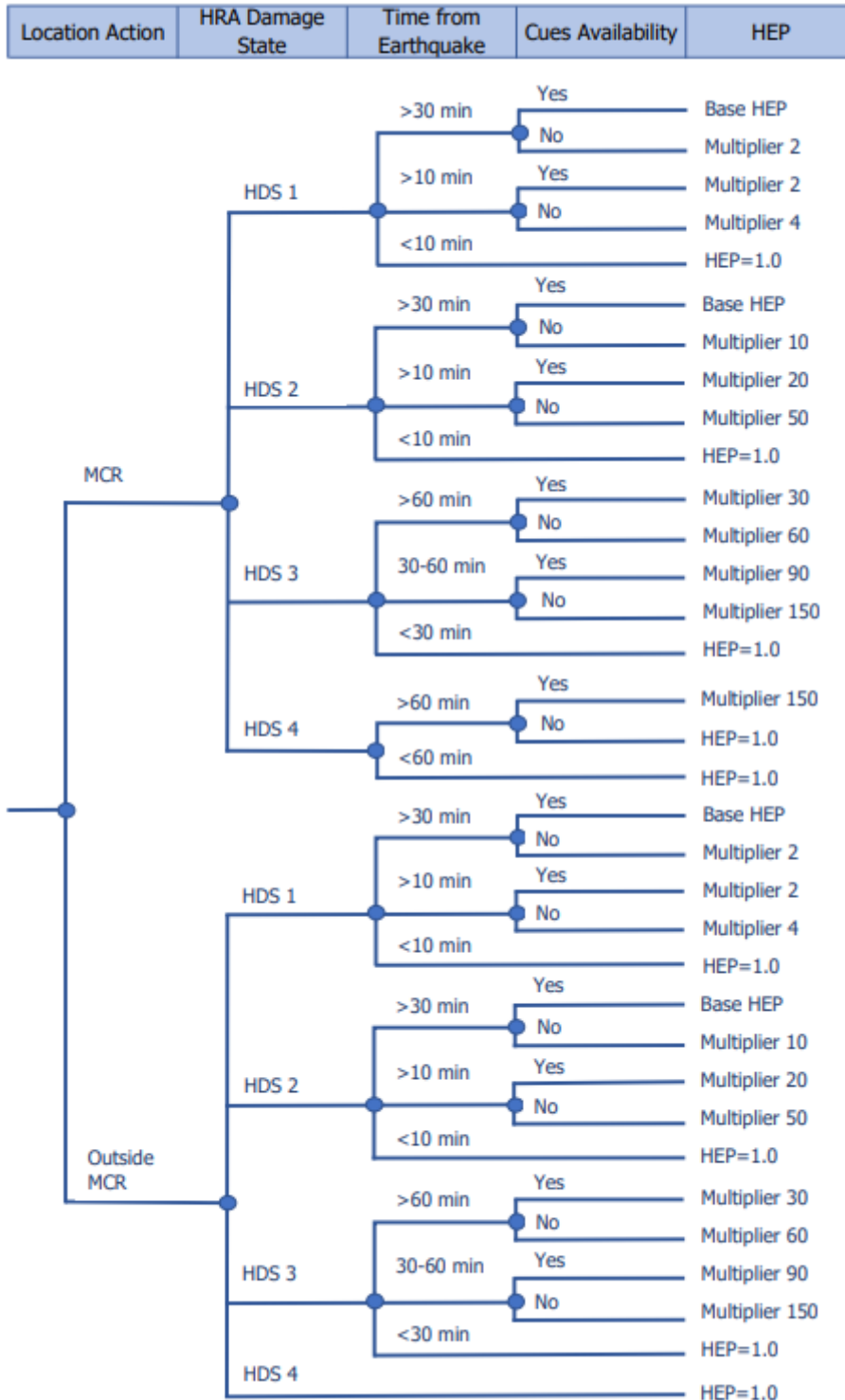

Figure 26: Calculation of the multipliers

Seismic HRA needs to include a more comprehensive and realistic assessment of influence of long-term post-core damage events. Long-term post-core damage sequences invoke new issues regarding the timing of operator actions. For example, in the Fukushima Dai-ichi accident, the opening of containment vent valves was unexpectedly delayed by several hours by: 1) waiting for a nearby town to be evacuated, 2) hardware failures, and 3) harsh environment conditions that developed during the waiting time. It was also noted that the arrival of additional resources (e.g. from offsite) did not ensure rapid situation control. For these prolonged scenarios, potential time delays need to be accounted for in a realistic manner. The lack of contingency procedures and pre-staged equipment impacted operator





actions, so that operators had to operate outside the procedural space or formal training. Relevant performance shaping factors, such as fatigue (e.g., operators in the Fukushima Dai-ichi event had long shifts with minimal food and rest) and “stress” in a very real sense (Fukushima Dai-ichi operators were clearly worried about their personal safety e.g. due to potential hydrogen explosions and because of irradiation and contamination on the site, facing the dilemma of social safety or loss of assets /TEPCO 2012/). Another potentially important aspect of long-term scenarios is the impact of shift changeover on the reliability of measure. Shift changeovers may lead to a loss of information or situational awareness, thus inducing additional sources of human error. An additional important aspect of seismic long-term scenarios is consideration of aftershocks. As stated in /METIS 2024a/, emergency events to be taken into account are those that have occurred in the period from the reactor emergency shutdown caused by the mainshock to the transition to cold shutdown state - approximately 5 days, while more precise time frame may vary depending on design and operational practices. Aftershocks can be important from the worker safety point of view. Specific concerns are: delayed initiation of needed activities (e.g., plant damage surveys) and interrupted ongoing work activities including recovery actions. Coordination challenges have been experienced at NPPs (e.g., at Kashiwazaki-Kariwa (2007) and Onagava (2011)), and evacuation of some onsite personnel contributed to the lack of organizational knowledge (e.g., operation of equipment, location of items). This may have influence on modelling of human actions /METIS 2024a/.

6. Conclusions

This report provides a description of approaches used for consideration of correlated failures of systems, structures and components in probabilistic models for seismic PSA. The way forward for the METIS study case is proposed, including: selection of plant-specific components for analysis of correlations; conversion of correlation coefficients (intuitively understandable by seismic engineers) to common-cause beta factors, which are understandable by PSA practitioners; approach for modelling of correlations at the METIS tool (Andromeda-SCRAM). For ZNPP Unit 1 selected components relationships between beta-factor and correlation coefficients, depending on different PGA levels, have been calculated.

Application of PSHA vector-valued analyses and vector-valued fragility analyses for METIS study case has been discussed. Although vector-valued analyses can provide a higher level of accuracy than scalar analysis, the use of vector intensity measures often entails a cost that, in many cases, may outweigh the benefits of achieving a more precise prediction of engineering demand parameters. For this reason, the scalar analysis was selected to be applied for the case study.

Since human actions under seismic conditions are associated with high degree of uncertainties, impact of seismic events on human performance, as well different methods for human reliability analysis and their applicability for seismic PSA have been discussed. General scheme for calculation of human error probabilities, based on the probabilities from internal events PSA and importance of factors like seismic damage states, time from earthquake, location of actions was proposed for the METIS study case.





7. Bibliography

- /APSA 2015/ M. Kumar, J. Klug, R. Alzbutas, L. Burgazzi, M. Farcasiu, I. Ivanov, H. Kazuta, S. La Rovere, M. Nitoi, O. Sevbo, J. Vitazkova, S. Hustak, A. Wielenberg. Lessons of the Fukushima Dai-ichi accident for PSA. Technical report ASAMPSA_E / WP30 / D30.2 / 2015-08 (2015).
- /Bied 1998/ Bieder, C., Le-Bot. P., Desmares, E., Bonnet. J-L., Cara, F. “MERMOS: EDFs new advanced HRA method.” In Probabilistic Safety Assessment and Management (PSAM 4). A. Mosleh and R.A. Bari (Eds). Springer-Verlag. New York. 1998.
- /EESD 2019/ Kohrangi, M., Bazzurro, P., & Vamvatsikos, D. Conditional spectrum bidirectional record selection for risk assessment of 3D structures using scalar and vector IMs. Earthquake Engineering and Structural Dynamics, 48(9), 1066–1082. (2019).
- /EPRI 1984/ Hannaman. G.W.. and Spurgin. A.J. Systematic human action reliability procedure. Electric Power Research Institute. EPRINP-3583.1984.
- /EPRI 1990/ Spurgin, A. I., et al. Operator reliability experiments using power plant simulators. Electric Power Research Institute (EPRI). EPRI NP-6937. Vol. 1.1990.
- /EPRI 1992a/ Wakefield, D.J., Parry, G.W., Hannaman, G.W., and Spurgin, A. J. SHARP 1 – A revised systematic human action reliability procedure, EPRI TR-101711. Tier 2. Electric Power Research Institute. December 1992.
- /EPRI 1992b/ Parry, G., et al. An approach to the analysis of operator actions in PRA. Electric Power Research Institute (EPRI). EPRI TR-100259.1992.
- /EPRI 2003/ Seismic Probabilistic Risk Assessment Implementation Guide, EPRI Technical Report 1002989, Palo Alto, CA (2003).
- /EPRI 2013/ Seismic Probabilistic Risk Assessment Implementation Guide, EPRI Technical Report 3002000709, Palo Alto, CA (2013).
- /EPRI 2016/ An Approach to Human Reliability Analysis for External Events with a Focus on Seismic, EPRI Technical Report 3002008093, Palo Alto, CA (2016).
- /EPRI 2018/ Seismic Fragility and Seismic Margin Guidance for Seismic Probabilistic Risk Assessments 3002012994 Final Report, September 2018.





- /ESR 2023/ Cosmin-Spanoche, A., Ramos, M., Mosleh, A., Nishiono, K. The impact of seismic events on human reliability and Phoenix HRA methodology. Proceedings of the 33rd European Safety and Reliability Conference (ESREL 2023).
- /GEHL 2012/ P. Gehl, D. M. Seyed, J. Douglas, "Vector-valued fragility functions for seismic risk evaluation", Bulletin of Earthquake Engineering (2012), DOI 10.1007/s10518-012-9402-7, 2012.
- /Holl 1998/ Hollnagel, E. Cognitive reliability and error analysis method (CREAM). York: Elsevier Science. New York. 1998.
- /Hump 1995/ Humphreys. P. (1995). Human Reliability Assessor's Guide. Human Reliability in Factor's Group.
- /IAEA 2024/. International Atomic Energy Agency, IAEA, "Probabilistic Safety Assessment Benchmarks of Multi-unit, Multi-reactor Sites", IAEA TECDOC 2044, IAEA, Vienna (2024).
- /IAEA 2024a/. International Atomic Energy Agency, IAEA, "Evaluation of Design Robustness of Nuclear Installations Against External Hazards", IAEA TECDOC 2043, IAEA, Vienna (2024).
- /IAEA 1993/ International Atomic Energy Agency, Probabilistic safety assessment for seismic events, IAEA TECDOC-724, IAEA, Vienna (1993).
- /IAEA 2024/ International Atomic Energy Agency, Development and Application of Level 1 Probabilistic Safety Assessment for Nuclear Power Plants, IAEA Safety Standards Series No. SSG-3, Rev. 1, IAEA, Vienna (2024).
- /IAEA 2020/ International Atomic Energy Agency, IAEA, "Probabilistic Safety Assessment for Seismic Events", IAEA TECDOC 1937 , IAEA, Vienna (2020).
- /IEEE 1988/ Williams, J.C. A Data-based method for assessing and reducing human error to improve operational performance. In: Proceedings of IEEE Fourth Conference on Human Factors and Power Plants, New York. IEEE. 1988.
- /INAC 2017/ Lécio N. de Oliveira, Isaac José A. Luquetti dos Santos, Paulo V. R. Carvalho, A Review Of The Evolution Of Human Reliability Analysis Methods At Nuclear Industry, 2017 International Nuclear Atlantic Conference - INAC 2017.





- /ISCU 2015/ Jelena Pejovica, Srdjan Jankovic, Selection of Ground Motion Intensity Measure for Reinforced Concrete Structure. International Scientific Conference Urban Civil Engineering and Municipal Facilities, Procedia Engineering 117 (2015) 588 – 595
- /Kaplan 1987/, S. Kaplan and J.C. Lin, “An Improved Condensation Procedure in Discrete Probability Distribution Calculations,” Risk Analysis, Vol, 7, No. 1, 1987.
- /Kirw 1994/ Kirwan, B. (1994) A Guide to Practical Human Reliability Assessment. CPC Press.
- /KNF 2016/Karl Fleming, Assessing the Seismic Risk of Small Modular Reactors. Presented to: CRA’s 7th Risk Forum Stratford-upon-Avon UK October 5 and 6, 2016.
- /KNS 2019/Seong Kyu Park, Woo Sik Jung, Koo Sam Kim, Seismic Correlation Application Study with COREX, Transactions of the Korean Nuclear Society Spring Meeting Jeju, Korea, May 23-24, 2019.
- /KOV 2014/ Kovacs Z., Probabilistic Safety Assessment of WWER440 Reactors - Prediction, Quantification and Management of the Risk, Springer Cham Heidelberg New York Dordrecht London ISBN 978-3-319-08547-0, Switzerland 2014, pp. 1-5, 85, 195.
- /METIS 2020/ M. GROS, N. Sipci, P. García de Quevedo Inarritu, L. Alvarez-Sanchez Luis, M. Kohrang, P. Bazzurro “Methodology for site specific rockhazard consistent record”, Horizon 2020 project METIS, Deliverable D5.1, 2020.
- /METIS 2021/ Sevbo O., “Definition and classification scheme of SSCs for specific and generic seismic fragility evaluation”, Horizon 2020 project METIS, Deliverable D6.1, 2021.
- /METIS 2023/ M. PAGANI, T. Chartier, A. Rood, “D4.6 - Preparation of the METIS study case (WP4) and application”, Horizon 2020 project METIS, Deliverable D4.6, 2023.
- /METIS 2024/ D. BOUHJITI, T. MENG, B. RICHARD, “Application of Bayesian updating techniques to the seismic fragility of nuclear structures, case of SMART2013 mockup”, Horizon 2020 project METIS, Deliverable D6.6, 2024.
- /METIS 2024a/ Ryzhov D., Ponochovnyi O., Fathabadi S., Styron R., “Strategy for consideration of aftershocks in seismic PSA”, Horizon 2020 project METIS, Deliverable D7.4, 2024.
- /METIS 2024b/ PAGANI M., Styron R., Johnson K., Simionato M., “New PSHA methodologies: code developments and documentation” Horizon 2020 project METIS, Deliverable D4.4, 2024.





- /Meye 2017/ Meyer, P., Le Bot, P., Pesme, H. MERMOS: an extended second generation HRA method. Industrial Risk Management Department, EDF R&D, Clamart, France. 2017.
- /NAR 2019/ Pierre Gehl, Jérémy Rohmer, Irmela Zentner, Karol Kowal, Sławomir Potempski, Cyril Feau, Marine Marcilhac-Fradin, Yves Guigueno, Manuel Pellissetti, James Daniell, Del2.6 – Methodology to derive vector-based fragility functions I: theoretical aspects, NARSIS project, 2019.
- /NEAT 2020/ W.S. Jung, K. Hwang, S.K. Park, A new methodology for modelling explicit seismic common cause failures for seismic multi-unit probabilistic safety assessment, Nuclear Engineering and Technology (2020), doi: <https://doi.org/10.1016/j.net.2020.03.023>.
- /NEAT 2021/Seunghyun Eem, In-Kil Choi, Beomjoo Yang, Shinyoung Kwag, Methodology of seismic-response-correlation-coefficient calculation for seismic probabilistic safety assessment of multi-unit nuclear power plants, Nuclear Engineering and Technology, Volume 53, Issue 3,2021, pages 967-973, ISSN 1738-5733.
- /NEAT 2021a/Yukihiko Kirimoto, Yuko Hirotsu, Kohei Nonose, Kunihide Sasou, Development of a human reliability analysis (HRA) guide for qualitative analysis with emphasis on narratives and models for tasks in extreme conditions, Nuclear Engineering and Technology, Volume 53, Issue 2, 2021, Pages 376-385, ISSN 1738-5733, <https://doi.org/10.1016/j.net.2020.10.004>.
- /NENE 2021/ Manuel Pellissetti, Marie-Cécile Robin-Boudaoud, Pierre Gehl, Seismic Fragility Analysis Based On Vector-Valued Intensity Measures; Theory And Application To Fuel Assembly Grids, 30th International Conference Nuclear Energy for New Europe (NENE2021).
- /NUR 1983/ Swain, A.D., and Guttman, H.E. Handbook of human reliability analysis with emphasis on nuclear power plant applications - final report, NUREG/CR-1278, SAND80-0200, Sandia National Laboratories, August 1983.
- /NUR 1984/ Embrey, D.E., Humphreys, P., Rosa, E.A., Kirwan, B. and Rea, K. SLIM-MAUD: An approach to assessing human error probabilities using structured expert judgment (Vols. I AU). NUREG/CR-3518, Brookhaven National Laboratory. Upton. NY. 1984.





- /NUR 1986/ Cummings G.E., "Summary Report on the Seismic Safety Margins Research Program", NUREG/CR-4431, Lawrence Livermore National Laboratory, Livermore, CA.
- /NUR 1987a/ Swain, A.D. Accident sequence evaluation program human reliability analysis procedure, NUREG/CR-4772, SAND86-1996. Sandia National Laboratories. February 1987.
- /NUR 1987b/ Whitehead, D. W. Recovery actions in PRA for the Risk Methods Integration and Evaluation Program (RMIEP), Volume 2: Application of the Data-Based Method, NUREG/CR-4834. Vol. 2, U.S. Nuclear Regulatory Commission. Washington. DC. 1987.
- /NUR 1990/ Severe Accident Risks: An Assessment for Five U.S. Nuclear Power Plants, NUREG-1150, 1990
- /NUR 1990a/ Bohn, M.P., J.A. Lambricht, "Procedures for the External Event Core Damage Frequency Analyses for NUREG-1150," NUREG/CR-4840, SAND88-3102, Sandia National Laboratories, Albuquerque, NM (1990)
- /NUR 2000/ Technical basis and implementation guidelines for A Technique for Human Event Analysis (ATHEANA), NUREG-1624. Rev. 1, US Nuclear Regulatory Commission. Washington. D.C., May 2000.
- /NUR 2000/ Technical Basis and Implementation Guidelines for A Technique for Human Event Analysis (ATHEANA), NUREG-1624, Rev. 1 (2000).
- /NUR 2005/ Gertman, D.I., Blackman, H.S., Byers. J., Haney, L., Smith, C., and Marble, J. "The SPAR-H Method. NUREG/CR-6883. U.S. Nuclear Regulator Commission. Washington. DC. August 2005.
- /NUR 2006/ J. Forester, A. Kolaczowski, E. Lois, D. Kelly, Evaluation of Human Reliability Analysis Methods Against Good Practices, NUREG – 1842, (2006)
- /NUR 2017a/ An Integrated Human Event Analysis System (IDHEAS) for Nuclear Power Plant Internal Events At-Power Application. Volume 1. NUREG-2199. Vol. 1. U.S. Nuclear Regulatory Commission, Office of Nuclear Regulatory Research, Washington, D.C. 20555-0001. Electric Power Research Institute, 3412 Hillview Avenue, Palo Alto, CA 94303. 2017.





- /NUR 2017/ Robert J. Budnitz, Gregory S. Hardy, David L. Moore, and M. K. Ravindra. Correlation of Seismic Performance in Similar SSCs (Structures, Systems, and Components, NUREG-7237 (2017).
- /NUS 1983/ Karimi R., “SEISMIC – A Computer Program for Seismic Risk Evaluation,” Report NUS-4064, NUS Corporation, Gaithersburg, MD, (1983).
- /OECD 1999/ Fleming, K.N., Mikschl, T.J., “Technical issues in the treatment of dependence in seismic risk analysis”, OECD/NEA Workshop on Seismic Risk (Proc. Tokyo, 1999), NEA/CSNI/R(99)28, OECD, Paris (2001) 253–268.
- /PSA 2019/McSweeney L. Seismic correlation modelling in multi-module PRAs. In: ANS International Topical Meeting on Probabilistic Safety Assessment; 2019. April 28-May 3.
- /PSAM 2013/ Nathan Siu, Don Marksberry, Susan Cooper, Kevin Coyne, Martin Stutzke, “PSA Technology Challenges Revealed by the Great East Japan Earthquake”, PSAM Topical Conference in Light of the Fukushima Dai-Ichi Accident Tokyo, Japan, April 15-17, 2013.
- /PSAM 2018/ Hayat Chatria, Smain Yalaouia, and Yolande Akl, Human Reliability Analysis (HRA) methodologies used in the Canadian Probabilistic Safety Assessment (PSA) for external events. Probabilistic Safety Assessment and Management PSAM 14, September 2018, Los Angeles, CA.
- /Reed 1985/ Reed, J.W., Mc Cann, M.W. Jr., Iihara, J., & Tamjed, H.H. Analytical techniques for performing probabilistic seismic risk assessment of nuclear power plants. in Proceedings of the International Conference on Structural Safety and Reliability (ICOSSAR’85), Vol. 3, pp. 253–261. United States: International Association for Structural Safety and Reliability, 1985.
- /RESS 2016/ Ekanem, N., Mosleh, A., Shen, S.-H. Phoenix – A model-based Human Reliability Analysis methodology: Qualitative Analysis Procedure. Reliability Engineering and System Safety, 145, 301–315, 2016.
- /RESS 2021/ Halil Sezen, J. Hur, C. Smith, T. Aldemir, R. Denning, A computational risk assessment approach to the integration of seismic and flooding hazards with internal hazards, Nuclear Engineering and Design, Volume 355, (2019), 110341, ISSN 0029-5493, <https://doi.org/10.1016/j.nucengdes.2019.110341>.





- /RESS 2024/ Taotao Zhou, Laibin Zhang, Jinqiu Hu, Mohammad Modarres, Enrique Lopez Droguett, “A Critical Review and Benchmark Study of Dependency Modelling for Seismic Probabilistic Risk Assessment in the Nuclear Power Industry”, Reliability Engineering & System Safety, Volume 245, ISSN 0951-8320, <https://doi.org/10.1016/j.ress.2024.110009>, 2024.
- /RESS 2024a/ Ekanem, N., Mosleh, A., Shen, S.-H., Ramos, M. Phoenix – A model-based Human Reliability Analysis methodology: Data sources and quantitative analysis procedure. Reliability Engineering & System Safety, Volume 248, August 2024, 110123.
- /SDEE 2018/ Ge, P.; Zhou, Y. Investigation of efficiency of vector-valued intensity measures for displacement-sensitive tall buildings. Soil Dynamics and Earthquake Engineering. 2018, 107, 417–424.
- /SMIRT 1991/ Yamaguchi A. Seismic fragility analysis of the heat transport system of LMFBR considering partial correlation of multiple failure modes. In: Transactions of the 11th international conference on structural mechanics in reactor technology; (1991).
- /SMIRT 2009/ Klügel, J.-U., “On the treatment of dependency of seismically induced component failures in seismic PRA”, Proceedings of 20th Conference on Structural Mechanics in Reactor Technology, SMIRT 20, 2009.
- /SMIRT 2011/ Pellissetti, U. Klapp, “Integration of Correlation Models for Seismic Failures into Fault Tree Based Seismic PSA”, Proceedings of 21th Conference on Structural Mechanics in Reactor Technology, SMiRT 21, New Delhi, India, 6-11 November, 2011.
- /SMIRT 2015/ Shunhao Ni, Zhen Cai, Wei-Chau Xie, Mahesh D. Pandey, Wei Liu, and Ming Han, Seismic Fragility Analysis For Structures, Systems, And Components Of Nuclear Power Plants: Part I — Issues Identified In Engineering Practice, Transactions, SMiRT-23 Manchester, United Kingdom - August 10-14, 2015.
- /SMIRT 2022/ Mohamed M. Talaat, Abhinav Anup, A Tail-Oriented Multi-Normal Model For Partially Correlated Seismic-Induced Failure Probabilities, Proceedings of 26th Conference on Structural Mechanics in Reactor Technology, SMiRT-26 Berlin/Potsdam, Germany, July 10-15, 2022.





- /SMIRT 2022a/ Abhinav Anup, Mohamed M. Talaat, Frederic F. Grant, Fernando Ferrante, Quantifying Partial Fragility Correlations In Seismic Probabilistic Risk Assessments, Proceedings of 26th Conference on Structural Mechanics in Reactor Technology, SMiRT-26 Berlin/Potsdam, Germany, July 10-15, 2022.
- /SMIRT 2022b/ K. Goldschmidt, H. Sadegh-Azar, O. Sevbo, B. Richard, A. Garcia de Quevedo Iñarrit, P. Bazzurro, D. Vamvatsikos, Innovative approaches for Seismic Fragility Analysis within METIS project. Proceedings of 26th Conference on Structural Mechanics in Reactor Technology, SMiRT-26 Berlin/Potsdam, Germany, July 10-15, 2022.
- /SMIRT 2022c/ Ram Srinivasan, Robert T. Sewell, Gabriel R. Toro, Observations from recent seismic PRAs in USA. Proceedings of 26th Conference on Structural Mechanics in Reactor Technology, SMiRT-26 Berlin/Potsdam, Germany, July 10-15, 2022 .
- /SMIRT 2022d/ Abhinav Anup, Mohamed M. Talaat, A modified hybrid method for developing seismic fragilities. Proceedings of 26th Conference on Structural Mechanics in Reactor Technology, SMiRT-26 Berlin/Potsdam, Germany, July 10-15, 2022.
- /SSM 2017/ Tuomas Mankamo. Extended Common Load Model: A tool for dependent failure modelling in highly redundant structures, Swedish Radiation Safety Authority, SSM 2017:11 ISSN: 2000-0456
- /TEPCO 2012/ Tokyo Electric Power Company, Inc. (TEPCO), "Fukushima Nuclear Accident Analysis Report", June 20, 2012, http://www.tepco.co.jp/en/press/corp-com/release/betu12_e/images/120620e0104.pdf.
- /VTT 1977/ Tuomas Mankamo. Common load model. A tool for common cause failure analysis. VTT Technical Research Centre of Finland. Valtion teknillinen tutkimuskeskus: Sähkötekniikan laboratorio. Tiedonanto No. 31, 1977.
- /Wang 2015/ Zhaoliang Wang, Seismic Risk Analysis for Nuclear Energy Facilities. A thesis presented to the University of Waterloo in fulfilment of the thesis requirement for the degree of Doctor of Philosophy in Civil Engineering, Waterloo, Ontario, Canada, 2015.





/Zhen 2018/ Zhen C, Wei-Chau X, Mahesh D P. Improving Seismic Margin Assessment Procedure using Multiple Ground Motion Parameters. Civil Engineering Research Journal. 2018; 5(1): 555652. DOI: 10.19080/CERJ.2018.05.555652.

/Zhou 2017/ Zhou T, Modarres M, Droguett EL. Issues in dependency modelling in multi-unit seismic PRA. In: ANS International Topical Meeting on Probabilistic Safety Assessment; 2017. September 24-28.

/Zhou 2018/ Taotao Zhou, Mohammad Modarres, Enrique López Droguett, An improved multi-unit nuclear plant seismic probabilistic risk assessment approach, Reliability Engineering & System Safety, Volume 171, 2018, Pages 34-47, ISSN 0951-8320, <https://doi.org/10.1016/j.ress.2017.11.015>.

/ZNPP 2019/ Zaporizhzhie NPP. Probabilistic safety assessment of seismic impact on power unit 1. Final report (in Russian). AT75/208-13.1000.ОД.4 (2019).

